

Robit[®]

DTH PRODUCTION DRILLING CATALOGUE

- Blasthole hammers
- RC hammers
- DTH bits



FURTHER. FASTER.

HAMMER ASSEMBLY

D35 IR3.5 2³/₈" API REG



1102209 D35 IR3.5 2³/₈" API REG HAMMER ASSEMBLY

1	1104328	Top Sub 2 ³ / ₈ " API Reg Pin
2	1042931	Check Valve Plunger
3	1042932	Check Valve Spring
4	1104776	Check Valve Holder
5	1232398	Make Up Block
6	1204101	Rubber Make Up Ring (x2)
7	1102119	Split Bush
8	1104486	Control Tube (Blank Choke Fitted)
9	1104497	Locking Ring
10	1102207	Piston
11	1102205	Cylinder
12	1104487	Drive Sub Bush
13	1102204	Bit Retaining Ring
14	1102201	Drive Sub Tungsten Armoured
15	1104329	Choke Kit (Not Shown)

	1107747	IR3.5 Exhaust Tube
	1270055	O Ring Kit
	1270056	Make Up Kit
	1270048	External Rebuild Kit, 2 ³ / ₈ " API Reg Pin
	1270049	Internal Rebuild Kit

Specifications

Bit Shank	IR3.5
Bit Range	3 ³ / ₄ " - 95mm to 4 ¹ / ₈ " - 105mm
Top Sub Thread	2 ³ / ₈ " API Reg Pin
Spanner Flat	2.51" - 64mm
Overall Length S/S	34" - 863.5mm
Weight (less bit)	70lbs - 32kg
Cylinder O.D.	3.34" - 85mm
Cylinder O.D. min	3.11" - 79mm
Oil Consumption	1.0 - 1.5 litres per hour

Air Pressure

Air Consumption

PSI	bar	CFM	m ³ /min
100	6.9	133	3.7
250	17.2	360	10.2
300	20.7	444	12.6
350	24.1	520	14.7
400	27.5	612	17.3

Robit[®]
www.robitegroup.com

sales@robitegroup.com

D35 IR3.5 2 3/8 API REG ASSY 1102209

HAMMER ASSEMBLY

D45 D340 2³/₈" API REG



1054806 D45 D340 2³/₈" API REG HAMMER ASSEMBLY

1	1054807	Top Sub, 2 3/8" API Reg Pin
2	1042931	Check Valve Plunger
3	1042932	Check Valve Spring
4	1104341	Check Valve Holder
5	1232387	Make Up Block
6	1054809	Rubber Make Up Ring (x2)
7	1054810	Split Bush
8	1042930	Control Tube (Blank Choke Fitted)
9	1053469	Locking Ring
10	1054811	D340 Piston
11	1242230	Cylinder
12	1054813	D340 Bit Retaining Ring
13	1054814	D340 Drive Sub Tungsten Armoured
14	1104329	Choke Kit (Not Shown)

	1054816	D340 Exhaust Tube
	1104361	O Ring Kit
	1261404	Make Up Kit
	1270050	External Rebuild Kit, 2 3/8" API Reg Pin
	1270052	Internal Rebuild Kit

Specifications

Bit Shank	DHD340
Bit Range	4 1/4" - 108mm to 5" - 127mm
Top Sub Thread	2 3/8" API Reg Pin
Spanner Flat	2.55" - 65mm
Overall Length S/S	40.7" - 1034mm
Weight (less bit)	84lbs - 38kg
Cylinder O.D.	3.85" - 98mm
Cylinder O.D. min	3.5" - 89mm
Oil Consumption	1.5 - 2.0 litres per hour

Air Pressure

Air Consumption

PSI	bar	CFM	m ³ /min
100	6.9	138	3.9
150	10.3	222	6.3
200	13.8	299	8.5
250	17.2	374	10.6
300	20.7	449	12.7
350	24.1	524	14.8
400	27.6	599	17.0
450	31.0	673	19.1
500	34.5	748	21.2

Robit[®]
www.robitegroup.com

sales@robitegroup.com

D45 D340 2 3/8 API REG ASSY 1054806

HAMMER ASSEMBLY

D45 D340 2 7/8" API REG



1057323 D45 D340 2 7/8" API REG HAMMER ASSEMBLY

1	1104349	Top Sub, 2 7/8" API Reg Pin
2	1042931	Check Valve Plunger
3	1042932	Check Valve Spring
4	1104341	Check Valve Holder
5	1232387	Make Up Block
6	1054809	Rubber Make Up Ring (x2)
7	1054810	Split Bush
8	1042930	Control Tube (Blank Choke Fitted)
9	1053469	Locking Ring
10	1054811	D340 Piston
11	1242230	Cylinder
12	1054813	D340 Bit Retaining Ring
13	1054814	D340 Drive Sub Tungsten Armoured
14	1104329	Choke Kit (Not Shown)

	1054816	D340 Exhaust Tube
	1104361	O Ring Kit
	1261404	Make Up Kit
	1270051	External Rebuild Kit, 2 7/8" API Reg Pin
	1270052	Internal Rebuild Kit

Specifications

Bit Shank	DHD340
Bit Range	4 1/4" - 108mm to 5" - 127mm
Top Sub Thread	2 7/8" API Reg Pin
Spanner Flat	2.55" - 65mm
Overall Length S/S	40.7" - 1034mm
Weight (less bit)	84lbs - 38kg
Cylinder O.D.	3.85" - 98mm
Cylinder O.D. min	3.5" - 89mm
Oil Consumption	1.5 - 2.0 litres per hour

Air Pressure

Air Consumption

PSI	bar	CFM	m ³ /min
100	6.9	138	3.9
150	10.3	222	6.3
200	13.8	299	8.5
250	17.2	374	10.6
300	20.7	449	12.7
350	24.1	524	14.8
400	27.6	599	17.0
450	31.0	673	19.1
500	34.5	748	21.2

Robit[®]
www.robitegroup.com

sales@robitegroup.com

D45 D340 2 7/8" API REG ASSY 1057323

HAMMER ASSEMBLY

D55 QL5 3 1/2" API REG



1



2



3

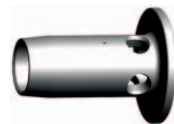

4

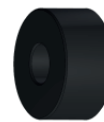

5

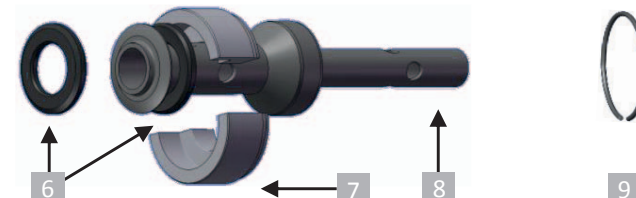

6

8

9

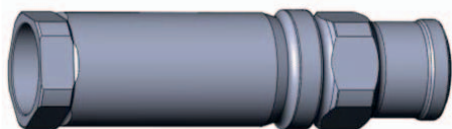

10



11



12



13

14

1054773 D55 QL5 3 1/2" API REG HAMMER ASSEMBLY

1	1072824	Top Sub 3 1/2" API Reg Pin
2	1072823	Check Valve Plunger
3	1104897	Check Valve Spring
4	1104896	Check Valve Holder
5	1232350	Make Up Block
6	1054777	Rubber Make Up Ring (x2)
7	1062576	Split Bush
8	1104891	Control Tube
9	1104890	Locking Ring
10	1062572	QL5 Piston
11	1104889	Cylinder
12	1067965	QL5 Drive Sub Bush
13	1054776	QL5 Bit Retaining Ring
14	1054775	QL5 Drive Sub Tungsten Armoured

	1054116	QL5 Exhaust Tube
	1072825	O Ring Kit
	1106356	Make Up Kit
	1062535	External Rebuild Kit
	1270053	Internal Rebuild Kit

Specifications

Bit Shank	QL5
Bit Range	5 1/2" - 140mm to 6" - 152mm
Top Sub Thread	3 1/2" API Reg Pin
Spanner Flat	N/A
Overall Length S/S	45.07" - 1145mm
Weight (less bit)	126lbs - 57kg
Cylinder O.D.	4.96" - 126mm
Cylinder O.D. min	4.52" - 115mm
Oil Consumption	2 - 2.5 litres per hour

Air Pressure

Air Consumption

PSI	bar	CFM	m ³ /min
100	6.9	188	5.3
150	10.3	331	9.4
200	13.8	439	12.4
250	17.2	548	15.5
300	20.7	667	18.9
350	24.1	826	23.4
400	27.6	985	27.9
450	31.0	1144	32.4
500	34.5	1303	36.9

Robit[®]
www.robitegroup.com

sales@robitegroup.com

D55 QL5 3.5 API REG ASSY 1054773

HAMMER ASSEMBLY

D65 QL6 3½" API REG

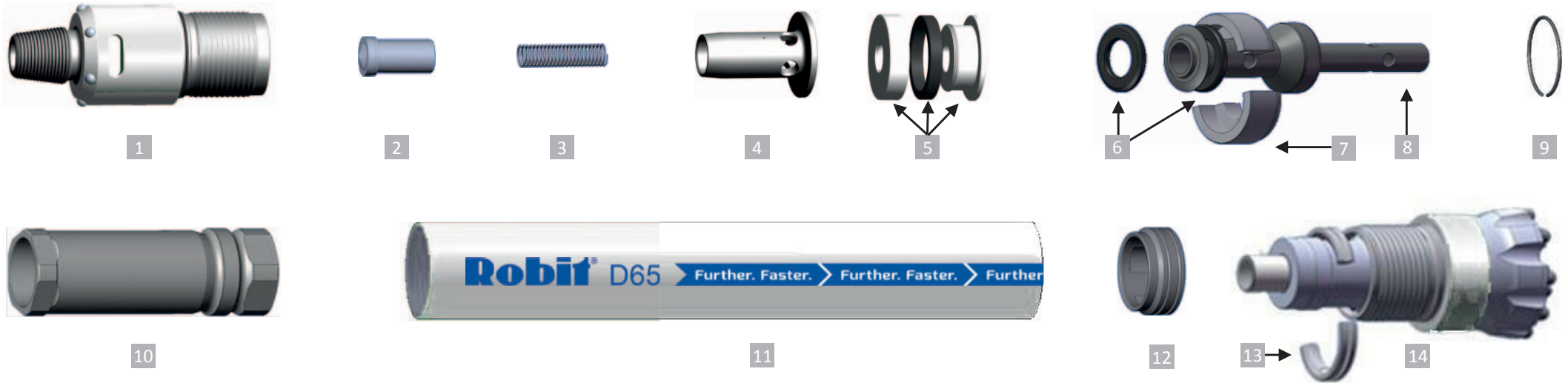

1023290 D65 QL6 3½" API REG HAMMER ASSEMBLY

1	1106875	Top Sub 3 ½" API Reg Pin
2	1062569	Check Valve Plunger
3	1065712	Check Valve Spring
4	1106857	Check Valve Holder
5	9001005	Make Up Assembly
6	1062562	Rubber Make Up Ring (x2)
7	1106853	Split Bush
8	1062538	Control Tube
9	1106393	Locking Ring
10	1065711	QL6 Piston
11	1065708	Cylinder
12	1065709	QL6 Drive Sub Bush
13	1062537	QL6 Bit Retaining Ring
14	1065706	QL6 Drive Sub Tungsten Armoured
	1077772	QL6 Exhaust Tube
	1106879	O Ring Kit
	1106880	Make Up Kit
	1067238	External Rebuild Kit
	1270054	Internal Rebuild Kit

Specifications

Bit Shank	QL6
Bit Range	6 ¼" - 159mm to 6 ¾" - 171mm
Top Sub Thread	3 ½" API Reg Pin
Spanner Flat	N/A
Overall Length S/S	45.54" - 1156.80mm
Weight (less bit)	222.74lbs - 101kg
Cylinder O.D.	5.75" - 146mm
Cylinder O.D. min	5.20" - 132mm
Oil Consumption	2.5 litres per hour

Air Pressure

Air Consumption

PSI	bar	CFM	m ³ /min
100	6.9	132	3.7
150	10.3	295	8.3
200	13.8	457	12.9
250	17.2	643	18.2
300	20.7	855	24.2
350	24.1	1041	29.5
400	27.6	1227	34.7
450	31.0	1413	40.0
500	34.5	1600	45.3

Robit[®]
www.robitchgroup.com

sales@robitchgroup.com

D65 QL6 3.5 API REG ASSY 1023290

HAMMER ASSEMBLY

D65 QL6 3½" API REG

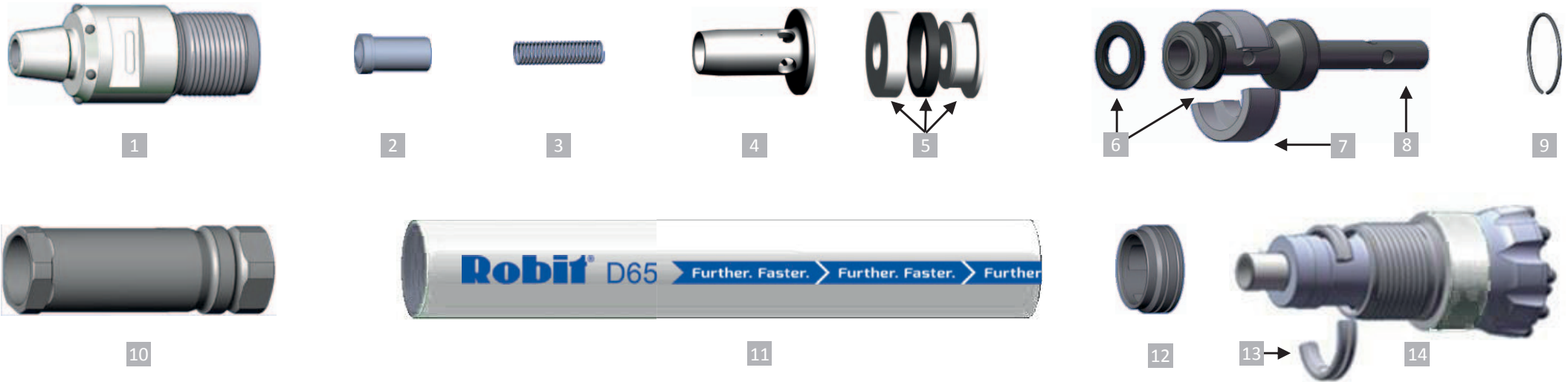

1280125 D65 QL6 3½" API REG HAMMER ASSEMBLY

1	1280126	Top Sub 3 ½" API Reg Pin with Flats
2	1062569	Check Valve Plunger
3	1065712	Check Valve Spring
4	1106857	Check Valve Holder
5	9001005	Make Up Assembly
6	1062562	Rubber Make Up Ring (x2)
7	1106853	Split Bush
8	1062538	Control Tube
9	1106393	Locking Ring
10	1065711	QL6 Piston
11	1065708	Cylinder
12	1065709	QL6 Drive Sub Bush
13	1062537	QL6 Bit Retaining Ring
14	1065706	QL6 Drive Sub Tungsten Armoured

	1077772	QL6 Exhaust Tube
	1106879	O Ring Kit
	1106880	Make Up Kit
		External Rebuild Kit
	1270054	Internal Rebuild Kit

Specifications

Bit Shank	QL6
Bit Range	6 ¼" - 159mm to 6 ¾" - 171mm
Top Sub Thread	3 ½" API Reg Pin
Spanner Flat	3.97" - 101mm x 1.96" 50mm
Overall Length S/S	45.54" - 1156.80mm
Weight (less bit)	222.74lbs - 101kg
Cylinder O.D.	5.75" - 146mm
Cylinder O.D. min	5.20" - 132mm
Oil Consumption	2.5 litres per hour

Air Pressure

Air Consumption

PSI	bar	CFM	m ³ /min
100	6.9	132	3.7
150	10.3	295	8.3
200	13.8	457	12.9
250	17.2	643	18.2
300	20.7	855	24.2
350	24.1	1041	29.5
400	27.6	1227	34.7
450	31.0	1413	40.0
500	34.5	1600	45.3

Robit[®]
www.robitegroup.com

sales@robitegroup.com

D65 QL6 3.5 API REG WITH FLATS ASSY 1280125

HAMMER ASSEMBLY

D65 QL6 3½" API REG HEAVY DUTY

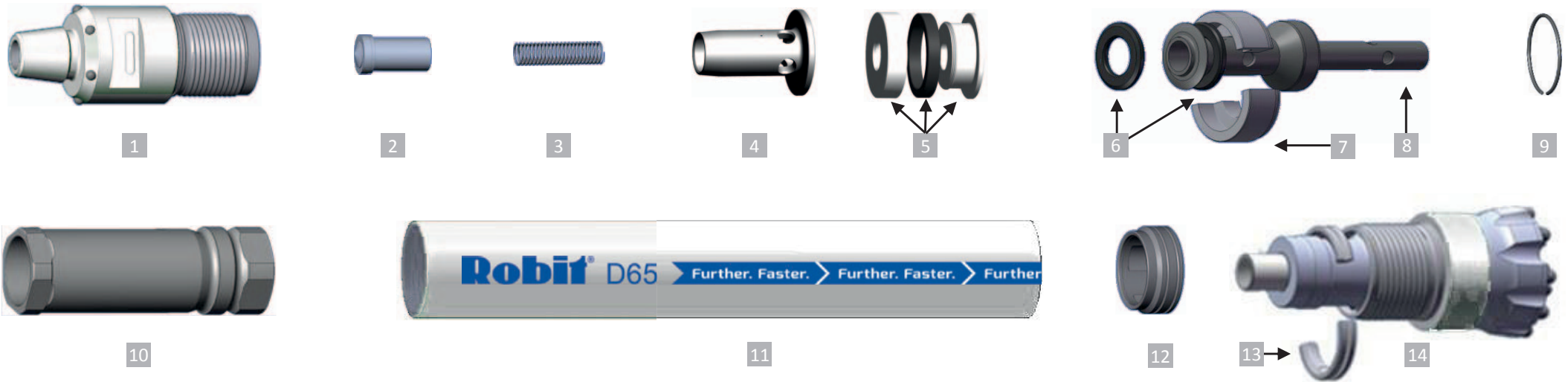

1280180 D65 QL6 3½" API REG HEAVY DUTY ASSEMBLY

1	1280181	Top Sub 3 ½" API Reg Pin HD with Flats
2	1062569	Check Valve Plunger
3	1065712	Check Valve Spring
4	1106857	Check Valve Holder
5	9001005	Make Up Assembly
6	1062562	Rubber Make Up Ring (x2)
7	1106853	Split Bush
8	1062538	Control Tube
9	1106393	Locking Ring
10	1065711	QL6 Piston
11	1280179	Cylinder HD
12	1065709	QL6 Drive Sub Bush
13	1062537	QL6 Bit Retaining Ring
14	1280178	QL6 Drive Sub HD Tungsten Armoured
	1077772	QL6 Exhaust Tube
	1106879	O Ring Kit
	1106880	Make Up Kit
	1280193	External Rebuild Kit
	1270054	Internal Rebuild Kit

Specifications

Bit Shank	QL6
Bit Range	6 ¼" - 159mm to 6 ¾" - 171mm
Top Sub Thread	3 ½" API Reg Pin
Spanner Flat	3.97" - 101mm x 1.96" 50mm
Overall Length S/S	45.54" - 1156.80mm
Weight (less bit)	222.74lbs - 101kg
Cylinder O.D.	5.90" - 150mm
Cylinder O.D. min	5.20" - 132mm
Oil Consumption	2.5 litres per hour

Air Pressure

Air Consumption

PSI	bar	CFM	m ³ /min
100	6.9	132	3.7
150	10.3	295	8.3
200	13.8	457	12.9
250	17.2	643	18.2
300	20.7	855	24.2
350	24.1	1041	29.5
400	27.6	1227	34.7
450	31.0	1413	40.0
500	34.5	1600	45.3

Robit[®]
www.robitegroup.com

sales@robitegroup.com

D65 QL6 3.5 API REG WITH FLATS ASSY 1280125

HAMMER ASSEMBLY

D65 QL6 3½" BECO

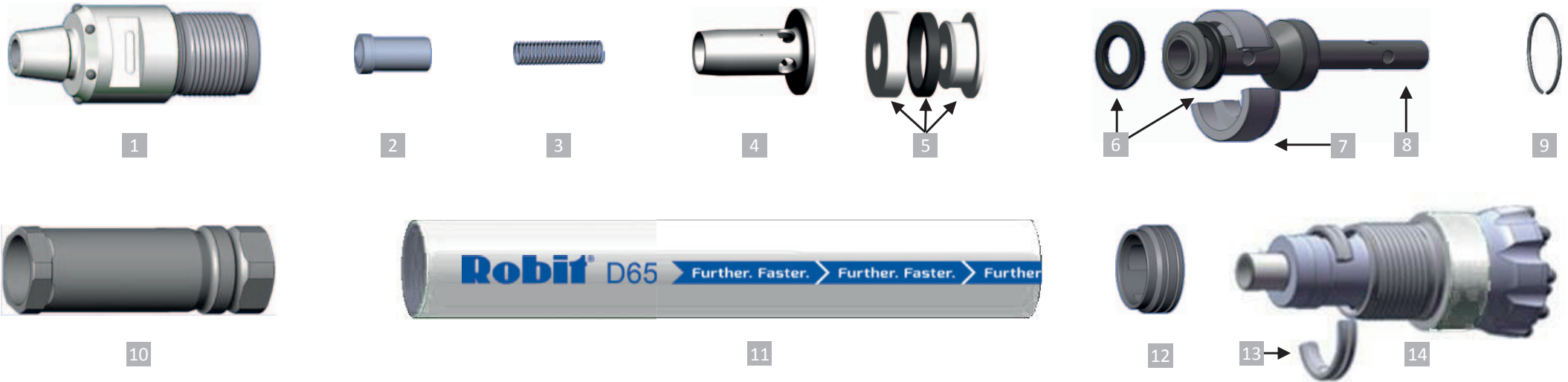

1280147 D65 QL6 3½" BECO HAMMER ASSEMBLY

Part No.	Description
1	1280148 Top Sub 3 ½" Beco Pin with Flats
2	1062569 Check Valve Plunger
3	1065712 Check Valve Spring
4	1106857 Check Valve Holder
5	9001005 Make Up Assembly
6	1062562 Rubber Make Up Ring (x2)
7	1106853 Split Bush
8	1062538 Control Tube
9	1106393 Locking Ring
10	1065711 QL6 Piston
11	1065708 Cylinder
12	1065709 QL6 Drive Sub Bush
13	1062537 QL6 Bit Retaining Ring
14	1065706 QL6 Drive Sub Tungsten Armoured

1077772	QL6 Exhaust Tube
1106879	O Ring Kit
1106880	Make Up Kit
	External Rebuild Kit
1270054	Internal Rebuild Kit

Specifications

Bit Shank	QL6
Bit Range	6 ¼" - 159mm to 6 ¾" - 171mm
Top Sub Thread	3 ½" Beco Pin
Spanner Flat	3.97" - 101mm x 1.96" 50mm
Overall Length S/S	45.54" - 1156.80mm
Weight (less bit)	222.74lbs - 101kg
Cylinder O.D.	5.75" - 146mm
Cylinder O.D. min	5.20" - 132mm
Oil Consumption	2.5 litres per hour

Air Pressure

Air Consumption

PSI	bar	CFM	m ³ /min
100	6.9	132	3.7
150	10.3	295	8.3
200	13.8	457	12.9
250	17.2	643	18.2
300	20.7	855	24.2
350	24.1	1041	29.5
400	27.6	1227	34.7
450	31.0	1413	40.0
500	34.5	1600	45.3

Robit[®]
www.robitegroup.com

sales@robitegroup.com

D65 QL6 3.5 BECO WITH FLATS ASSY 1280147

HAMMER ASSEMBLY

D65 W QL6 3½" API REG

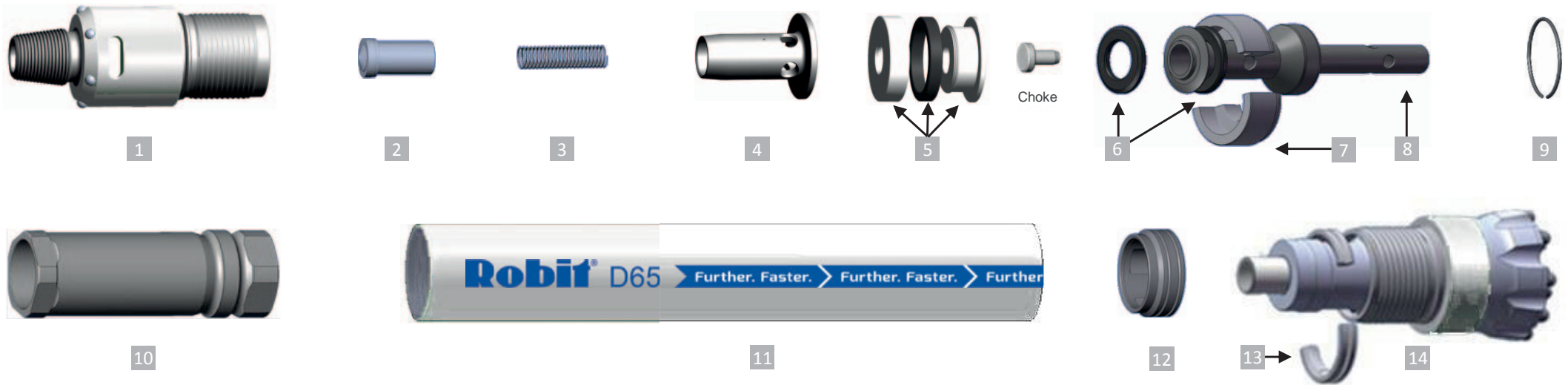

1117496 D65 W QL6 3½" API REG HAMMER ASSEMBLY

1	1106875	Top Sub 3 ½" API Reg Pin
2	1062569	Check Valve Plunger
3	1065712	Check Valve Spring
4	1106857	Check Valve Holder
5	9001005	Make Up Assembly
6	1062562	Rubber Make Up Ring (x2)
7	1106853	Split Bush
8	1106852	Control Tube (Blank Choke Fitted)
9	1106393	Locking Ring
10	1065711	QL6 Piston
11	1065708	Cylinder
12	1065709	QL6 Drive Sub Bush
13	1062537	QL6 Bit Retaining Ring
14	1065706	QL6 Drive Sub Tungsten Armoured
15	1106357	Choke Kit (Not Shown)

	1077772	QL6 Exhaust Tube
	1106879	O Ring Kit
	1106880	Make Up Kit
	1067238	External Rebuild Kit

Specifications

Bit Shank	QL6
Bit Range	6 ¼" - 159mm to 6 ¾" - 171mm
Top Sub Thread	3 ½" API Reg Pin
Spanner Flat	N/A
Overall Length S/S	45.54" - 1156.80mm
Weight (less bit)	222.74lbs - 101kg
Cylinder O.D.	5.75" - 146mm
Cylinder O.D. min	5.20" - 132mm
Oil Consumption	2.5 litres per hour

Air Pressure

PSI	Air Consumption		
	bar	CFM	m ³ /min
100	6.9	132	3.7
200	13.8	457	12.9
300	20.7	855	24.2
400	27.6	1227	34.7
500	34.5	1600	45.3

Chokes - Air consumption (CFM) at a given pressure

Size	PSI	150	200	250	300	350
1/8" - 3mm		20	30	40	50	60
3/16" - 4.5mm		55	65	85	105	125
1/4" - 6mm		80	105	140	175	210

Robit[®]
www.robitegroup.com

sales@robitegroup.com

D65 W QL6 3.5 API REG ASSY 1117496

HAMMER ASSEMBLY

D75 D75 4½" API REG

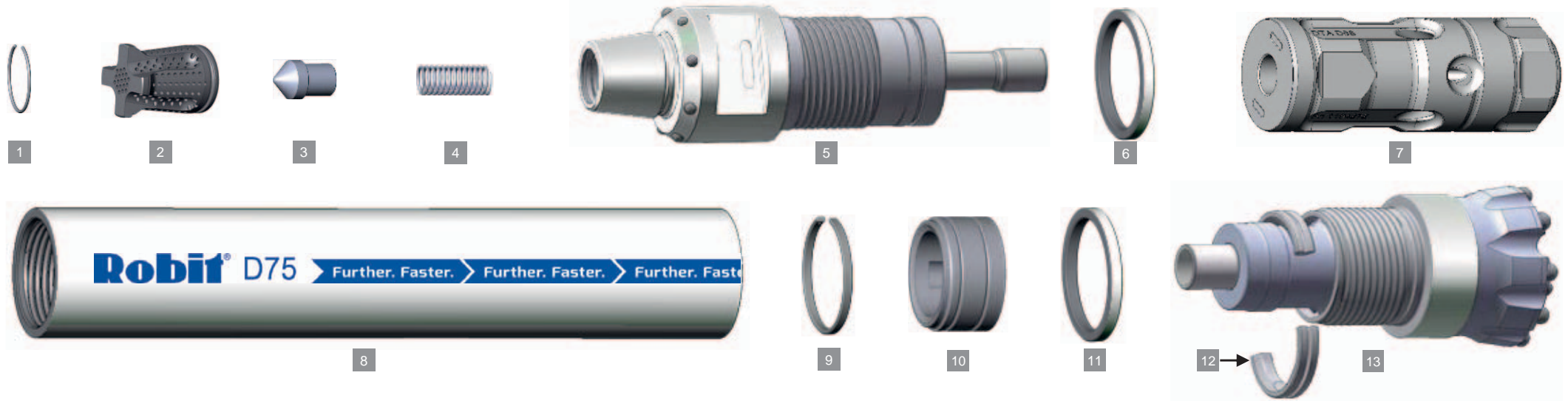

1261110 D75 D75 4½" API REG HAMMER ASSEMBLY

1	1016402	Check Valve Screen Retainer
2	1016401	Check Valve Screen
3	1016403	Check Valve Plunger
4	1016404	Check Valve Spring
5	1020822	Top Sub Assembly
6	1016400	Breakout Ring
7	1016397	D75 Piston
8	1020823	Cylinder Heavy Duty
9	1016398	Piston Retaining Ring
10	1218179	D75 Drive Sub Bush
11	1016400	Breakout Ring
12	1258180	D75 Bit Retaining Ring
13	1117836	D75 Drive Sub Tungsten Armoured
	1107744	D75 Exhaust Tube
	1016406	O Ring Kit

Specifications

Bit Shank	D75
Bit Range	8" - 203mm to 9" - 229mm
Top Sub Thread	4 ½" API Reg Pin
Spanner Flat	5" - 127mm x 2.75" - 70mm
Overall Length S/S	50" - 1276mm
Weight (less bit)	473 lbs - 215 kg
Cylinder O.D	6.95" - 176.5mm
Reverse Cylinder	6.5" - 165mm
Cylinder O.D min	6.2" - 157.5mm
Oil Consumption	2 - 4 litres per hour

Air Pressure

Air Consumption

PSI	bar	CFM	m ³ /min
100	6.9	314	8.9
150	10.3	497	14.1
200	13.8	680	19.2
250	17.2	864	24.4
300	20.7	1050	29.7
350	24.1	1230	34.8
400	27.6	1450	35.5

Robit[®]
www.robitegroup.com

sales@robitegroup.com

D75 ASSY HF DRIVE SUB 1261110

HAMMER ASSEMBLY

D84 QL80 4½" API REG

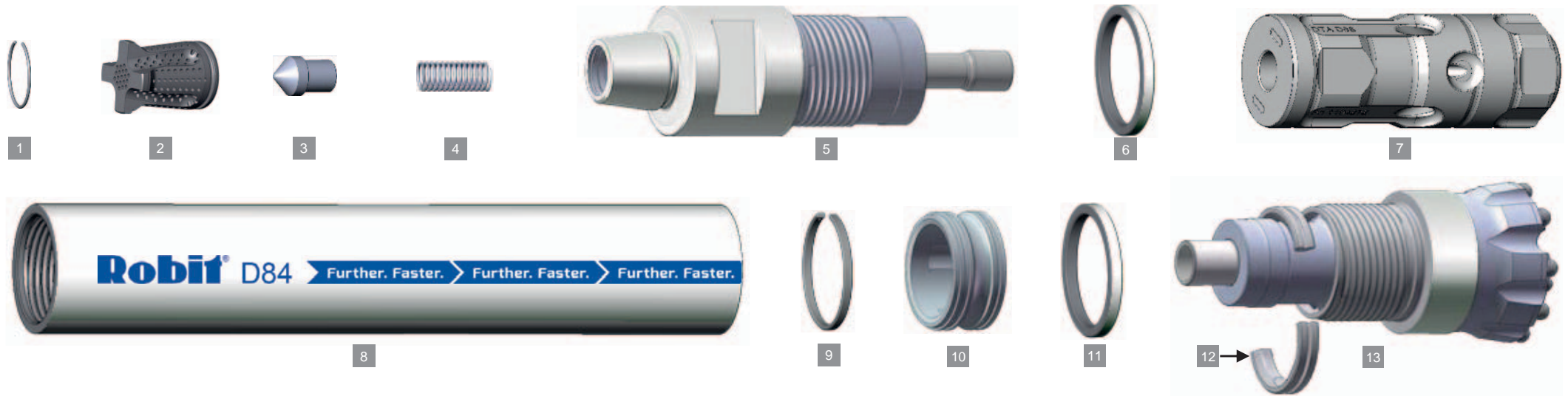

1108020 D84 QL80 4½" API REG HAMMER ASSEMBLY

1	1016402	Check Valve Screen Retainer
2	1016401	Check Valve Screen
3	1061460	Check Valve Plunger
4	1061459	Check Valve Spring
5	1104254	Top Sub Assembly 4½" API Reg
6	1101540	Breakout Ring
7	1061458	QL80 Piston
8	1101539	Cylinder Std
9	1101541	Piston Retaining Ring
10	1101537	QL80 Drive Sub Bush
11	1101540	Breakout Ring
12	1061457	QL80 Bit Retaining Ring
13	1101536	QL80 Drive Sub Std

	1259321	QL80 Open Choke Piston (Optional)
	1107750	QL80 Exhaust Tube
	1061461	O Ring Kit

Specifications

Bit Shank	QL80
Bit Range	8" - 203mm to 9" - 229mm
Top Sub Thread	4½" API Reg Pin
Spanner Flat	5" - 127mm x 2.75" - 70mm
Overall Length S/S	50.43" - 1281mm
Weight (less bit)	390lbs - 177kg
Cylinder O.D	7.20" - 183mm
Reverse Cylinder	6.81" - 173mm
Cylinder O.D min	6.45" - 164mm
Oil Consumption	4 - 4.5 litres per hour

Air Pressure

Air Consumption

PSI	bar	CFM	m³/min
100	6.9	350	8.9
150	10.3	552	15.4
200	13.8	755	21.1
250	17.2	960	26.8
300	20.7	1166	32.6
350	24.1	1367	38.2
400	27.6	1611	45.1

Robit[®]
www.robitegroup.com

sales@robitegroup.com

D84 QL80 STD ASSY 1108020

HAMMER ASSEMBLY

D84 QL80 4½" BECO

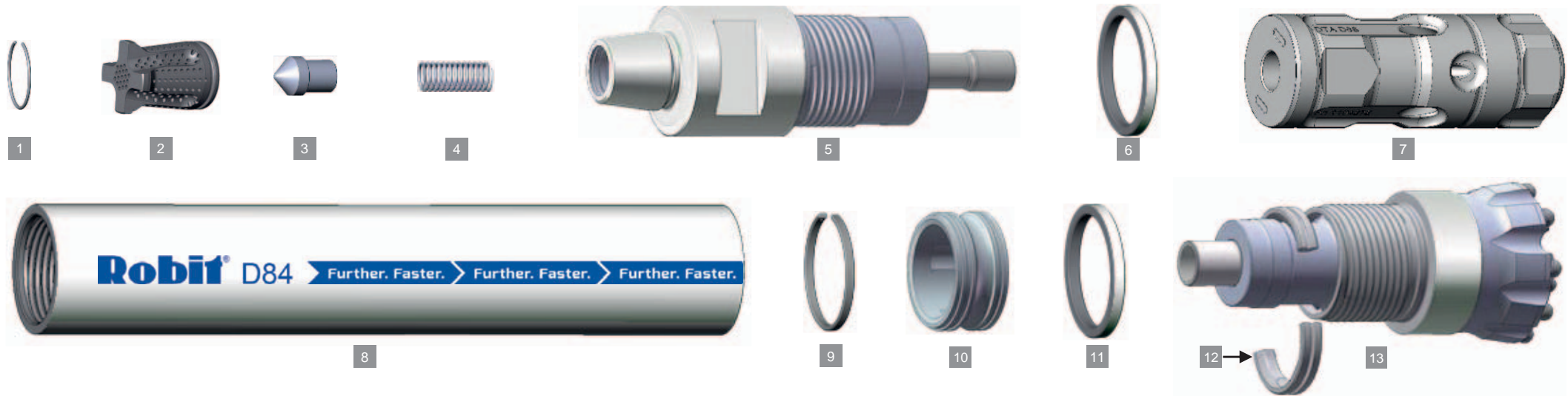

1117319 D84 QL80 4½" BECO PIN HAMMER ASSEMBLY

1	1016402	Check Valve Screen Retainer
2	1016401	Check Valve Screen
3	1061460	Check Valve Plunger
4	1061459	Check Valve Spring
5	1221162	Top Sub Assembly 4 ½" Beco
6	1101540	Breakout Ring
7	1061458	QL80 Piston
8	1101538	Cylinder
9	1101541	Piston Retaining Ring
10	1101537	QL80 Drive Sub Bush
11	1101540	Breakout Ring
12	1061457	QL80 Bit Retaining Ring
13	1061456	QL80 Drive Sub Tungsten Armoured
	1107750	QL80 Exhaust Tube
	1061461	O Ring Kit

Specifications

Bit Shank	QL80
Bit Range	8" - 203mm to 9" - 229mm
Top Sub Thread	4 ½" Beco Pin
Spanner Flat	5" - 127mm x 2.75" - 70mm
Overall Length S/S	50.43" - 1281mm
Weight (less bit)	390lbs - 177kg
Cylinder O.D	7.20" - 183mm
Reverse Cylinder	6.81" - 173mm
Cylinder O.D min	6.45" - 164mm
Oil Consumption	4 - 4.5 litres per hour

Air Pressure

Air Consumption

PSI	bar	CFM	m ³ /min
100	6.9	350	8.9
150	10.3	552	15.4
200	13.8	755	21.1
250	17.2	960	26.8
300	20.7	1166	32.6
350	24.1	1367	38.2
400	27.6	1611	45.1

Robit[®]
www.robitegroup.com

sales@robitegroup.com

D84 QL80 HD ASSY 4.5 BECO PIN 1117319

HAMMER ASSEMBLY

D84 QL80 4½" API REG RETENTION

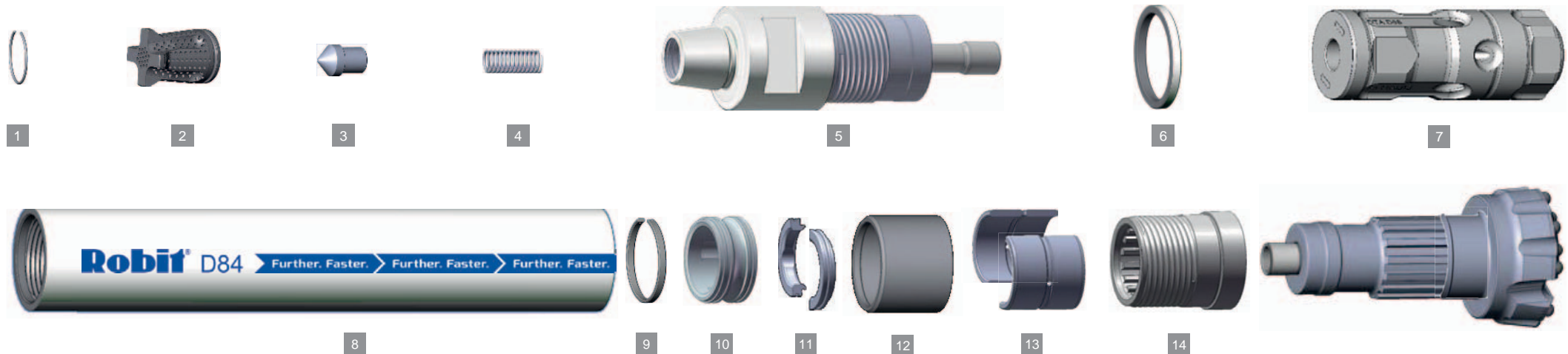

1108021 D84 QL80 4½" API REG RETENTION ASSEMBLY

1	1016402	Check Valve Screen Retainer
2	1016401	Check Valve Screen
3	1061460	Check Valve Plunger
4	1061459	Check Valve Spring
5	1104254	Top Sub Assembly 4 ½" API Reg
6	1101540	Breakout Ring
7	1061458	QL80 Piston
8	1101539	Cylinder Std
9	1101541	Piston Retaining Ring
10	1101537	QL80 Drive Sub Bush
11	1061457	QL80 Bit Retaining Ring
12	1104256	QL80 Retention Wear Collar
13	1104257	QL80 Retention Locking Collar
14	1117847	QL80 Drive Sub Retention

	1259321	QL80 Open Choke Piston (Optional)
	1107750	QL80 Exhaust Tube
	1061461	O Ring Kit

Specifications

Bit Shank	QL80
Bit Range	8" - 203mm to 9" - 229mm
Top Sub Thread	4 ½" API Reg Pin
Spanner Flat	5" - 127mm x 2.75" - 70mm
Overall Length S/S	50.43" - 1281mm
Weight (less bit)	390lbs - 177kg
Cylinder O.D	7.20" - 183mm
Reverse Cylinder	6.81" - 173mm
Cylinder O.D min	6.45" - 164mm
Oil Consumption	4 - 4.5 litres per hour

Air Pressure

Air Pressure		Air Consumption	
PSI	bar	CFM	m ³ /min
100	6.9	350	8.9
150	10.3	552	15.4
200	13.8	755	21.1
250	17.2	960	26.8
300	20.7	1166	32.6
350	24.1	1367	38.2
400	27.6	1611	45.1

Robit[®]
www.robgroup.com

sales@robgroup.com

D84 QL80 ASSY RETENTION 1108021

HAMMER ASSEMBLY

D88 QL80 4½" API REG



1066482 D88 QL80 4½" API REG HAMMER ASSEMBLY

1	1016402	Check Valve Screen Retainer
2	1016401	Check Valve Screen
3	1061460	Check Valve Plunger
4	1061459	Check Valve Spring
5	1104279	Top Sub Assembly 4 ½" API Reg
6	1104266	Breakout Ring
7	1061414	QL80 Piston
8	1104264	Cylinder
9	1104273	Piston Retaining Ring
10	1104261	QL80 Drive Sub Bush
11	1104266	Breakout Ring
12	1097056	QL80 Bit Retaining Ring
13	1104258	QL80 Drive Sub Tungsten Armoured
	1107750	QL80 Exhaust Tube
	1104288	O Ring Kit

Specifications

Bit Shank	QL80
Bit Range	8 ½" - 216mm to 9 ½" - 241mm
Top Sub Thread	4 ½" API Reg Pin
Spanner Flat	5" - 127mm x 2.75" - 70mm
Overall Length S/S	50" - 1276mm
Weight (less bit)	473lbs - 215kg
Cylinder O.D	7.6" - 194mm
Reverse Cylinder	7.2" - 184mm (if required)
Cylinder O.D min	6.8" - 174mm
Oil Consumption	4 - 4.5 litres per hour

Air Pressure

Air Consumption

PSI	bar	CFM	m ³ /min
100	6.9	370	10.3
150	10.3	585	16.3
200	13.8	800	22.4
250	17.2	1016	28.4
300	20.7	1235	34.5
350	24.1	1447	40.5
400	27.6	1706	47.7

Robit[®]
www.robgroup.com

sales@robgroup.com

D88 QL80 ASSY 1066482

HAMMER ASSEMBLY

D88 QL80 4½" API REG



1101399 D88 QL80 4½" BECO PIN HAMMER ASSEMBLY

1	1016402	Check Valve Screen Retainer
2	1016401	Check Valve Screen
3	1061460	Check Valve Plunger
4	1061459	Check Valve Spring
5	1101397	Top Sub Assembly 4½" Beco
6	1104266	Breakout Ring
7	1061414	QL80 Piston
8	1104264	Cylinder
9	1104273	Piston Retaining Ring
10	1104261	QL80 Drive Sub Bush
11	1104266	Breakout Ring
12	1097056	QL80 Bit Retaining Ring
13	1104258	QL80 Drive Sub Tungsten Armoured
	1107750	QL80 Exhaust Tube
	1104288	O Ring Kit

Specifications

Bit Shank	QL80
Bit Range	8½" - 216mm to 9½" - 241mm
Top Sub Thread	4½" Beco Pin
Spanner Flat	5" - 127mm x 2.75" - 70mm
Overall Length S/S	50" - 1276mm
Weight (less bit)	473lbs - 215kg
Cylinder O.D	7.6" - 194mm
Reverse Cylinder	7.2" - 184mm (if required)
Cylinder O.D min	6.8" - 174mm
Oil Consumption	4 - 4.5 litres per hour

Air Pressure

Air Consumption

PSI	bar	CFM	m ³ /min
100	6.9	370	10.3
150	10.3	585	16.3
200	13.8	800	22.4
250	17.2	1016	28.4
300	20.7	1235	34.5
350	24.1	1447	40.5
400	27.6	1706	47.7

Robit[®]
www.robitegroup.com

sales@robitegroup.com

D88 QL80 ASSY 4.5 BECO PIN 1101399

HAMMER ASSEMBLY

D97 QL80 4½" API REG

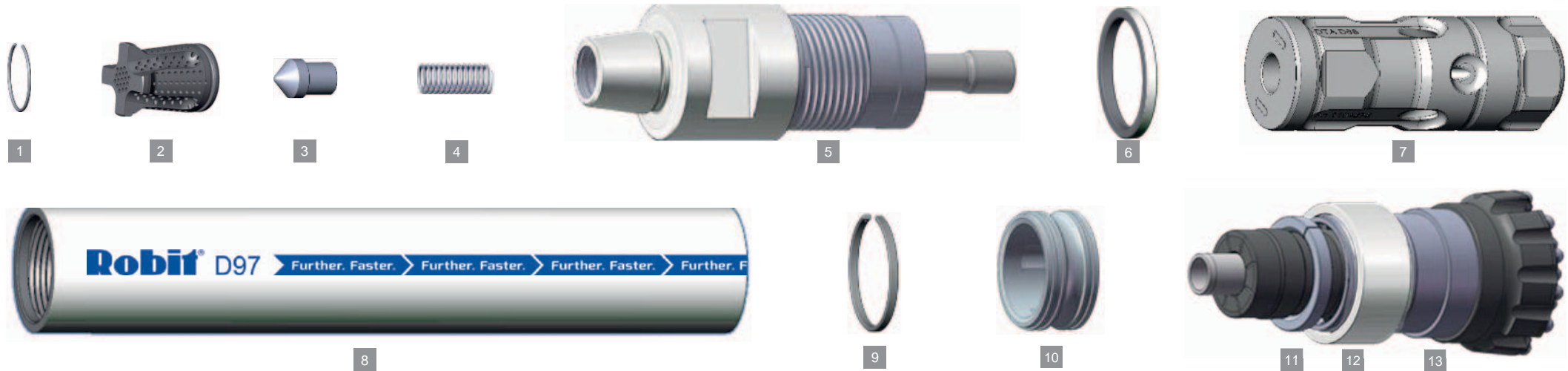

1119017 D97 QL80 4½" API REG HAMMER ASSEMBLY

1	1016402	Check Valve Screen Retainer
2	1016401	Check Valve Screen
3	1061460	Check Valve Plunger
4	1061459	Check Valve Spring
5	1174369	Top Sub Assembly 4 ½" API Reg
6	1174365	Breakout Ring
7	1061414	Piston
8	1174358	Cylinder
9	1104273	Piston Retaining Ring
10	1104261	Drive Sub Bush
11	1097056	Bit Retaining Ring
12	1174356	D97 Drive Sub Collar
13	1061413	Drive Sub Body
	1107750	QL80 Exhaust Tube
	1104288	O Ring Kit

Specifications

Bit Shank	QL80
Bit Range	9" - 229mm to 9 7/8" - 251mm
Top Sub Thread	4 ½" API Reg Pin
Spanner Flat	5" - 127mm x 2.75" - 70mm
Overall Length S/S	50" - 1276mm
Weight (less bit)	473lbs - 215kg
Cylinder O.D	8" - 203mm
Cylinder O.D min	7.2" - 183mm
Oil Consumption	4 - 4.5 litres per hour

Air Pressure

Air Consumption

PSI	bar	CFM	m ³ /min
100	6.9	370	10.3
150	10.3	585	16.3
200	13.8	800	22.4
250	17.2	1016	28.4
300	20.7	1235	34.5
350	24.1	1447	40.5
400	27.6	1706	47.7

Robit[®]
www.robitegroup.com

sales@robitegroup.com

D97 QL80 HD ASSY 1119017

DRILL BIT RANGE

IR3.5



HEAD DIAMETER (mm)	HEAD DIAMETER (inch)	FACE DESIGN	ITEM CODE	NUMBER OF PORTS	WEIGHT (kg)	BUTTON PROFILE	GAUGE ANGLE (°)	GAUGE CARBIDE QTY.	GAUGE CARBIDE DIA. (mm)	GAUGE CARBIDE DIA. (inch)	GAUGE CARBIDE GRADE	GAUGE 2 ANGLE (°)	GAUGE 2 CARBIDE QTY.	GAUGE 2 CARBIDE DIA. (mm)	GAUGE 2 CARBIDE DIA. (inch)	GAUGE 2 CARBIDE GRADE	FACE CARBIDE QTY.	FACE CARBIDE DIA. (mm)	FACE CARBIDE DIA. (inch)	FACE CARBIDE GRADE	CENTER CARBIDE QTY.	CENTER CARBIDE DIA. (mm)	CENTER CARBIDE DIA. (inch)	CENTER CARBIDE GRADE	CONE ANGLE (°)	CONE CARBIDE QTY.	CONE CARBIDE DIA. (mm)	CONE CARBIDE DIA. (inch)	CONE CARBIDE GRADE
108	4 1/4	CC	1100537	3	5	DM	35	9	12.7	1/2	G20	-	-	-	-	-	6	11	-	G20	-	-	-	-	-20	3	11	-	G20
108	4 1/4	CC	1280044	3	5	DM	35	9	12.7	1/2	PCD	-	-	-	-	-	6	11	-	G20	-	-	-	-	-20	3	11	-	G20

Robit[®]
www.robbitgroup.com

sales@robbitgroup.com
CONVENTIONAL DRILL BIT RANGE

DRILL BIT RANGE

DHD340



HEAD DIAMETER (mm)	HEAD DIAMETER (inch)	FACE DESIGN	ITEM CODE	NUMBER OF PORTS	WEIGHT (kg)	BUTTON PROFILE	GAUGE ANGLE (°)	GAUGE CARBIDE QTY.	GAUGE CARBIDE DIA. (mm)	GAUGE CARBIDE DIA. (inch)	GAUGE CARBIDE GRADE	GAUGE 2 ANGLE (°)	GAUGE 2 CARBIDE QTY.	GAUGE 2 CARBIDE DIA. (mm)	GAUGE 2 CARBIDE DIA. (inch)	GAUGE 2 CARBIDE GRADE	FACE CARBIDE QTY.	FACE CARBIDE DIA. (mm)	FACE CARBIDE DIA. (inch)	FACE CARBIDE GRADE	CENTER CARBIDE QTY.	CENTER CARBIDE DIA. (mm)	CENTER CARBIDE DIA. (inch)	CENTER CARBIDE GRADE	CONE ANGLE (°)	CONE CARBIDE QTY.	CONE CARBIDE DIA. (mm)	CONE CARBIDE DIA. (inch)	CONE CARBIDE GRADE
110	4 3/8	DC	1261573	4	7.7	DM	35	8	14.288	9/16	G20	-	-	-	-	-	4	14.288	9/16	G20	2	14.288	9/16	G20	-	-	-	-	-
110	4 3/8	FF	1262589	4	8.9	DM	35	8	15.875	5/8	G20	-	-	-	-	-	8	14.288	9/16	G20	-	-	-	-	-	-	-	-	-
110	4 3/8	CV	1280052	4	7.4	BA	35	8	11	-	G20	25	4	11	-	G20	4	11	-	G20	-	-	-	-	-	-	-	-	-
115	4 1/2	DC	1242440	4	7.9	DM	35	8	14.288	9/16	G20	-	-	-	-	-	4	14.288	9/16	G20	2	14.288	9/16	G20	-	-	-	-	-
115	4 1/2	FF	1262588	4	7.9	DM	40	8	14.288	9/16	G20	-	-	-	-	-	6	14.288	9/16	G20	-	-	-	-	-	-	-	-	-
127	5	DC	1249362	4	8.7	DM	35	8	15.875	5/8	G20	-	-	-	-	-	4	14.288	9/16	G20	4	14.288	9/16	G20	-	-	-	-	-
127	5	CC	1066967	3	8.6	DM	35	9	14.288	9/16	G20	-	-	-	-	-	6	12	-	G20	-	-	-	-	-15	4	12	-	G20

DRILL BIT RANGE

QL5

FF

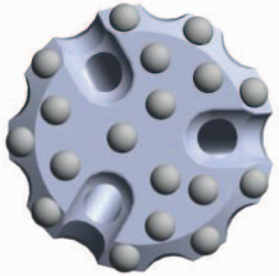

Flat Face

DC

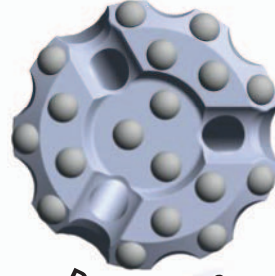

Drop Centre

CV



Convex

HEAD DIAMETER (mm)	HEAD DIAMETER (inch)	FACE DESIGN	ITEM CODE	NUMBER OF PORTS	WEIGHT (kg)	BUTTON PROFILE	GAUGE ANGLE (°)	GAUGE CARBIDE QTY.	GAUGE CARBIDE DIA. (mm)	GAUGE CARBIDE DIA. (inch)	GAUGE CARBIDE GRADE	GAUGE 2 ANGLE (°)	GAUGE 2 CARBIDE QTY.	GAUGE 2 CARBIDE DIA. (mm)	GAUGE 2 CARBIDE DIA. (inch)	GAUGE 2 CARBIDE GRADE	FACE CARBIDE QTY.	FACE CARBIDE DIA. (mm)	FACE CARBIDE DIA. (inch)	FACE CARBIDE GRADE	CENTER CARBIDE QTY.	CENTER CARBIDE DIA. (mm)	CENTER CARBIDE DIA. (inch)	CENTER CARBIDE GRADE	CONE ANGLE (°)	CONE CARBIDE QTY.	CONE CARBIDE DIA. (mm)	CONE CARBIDE DIA. (inch)	CONE CARBIDE GRADE	
140	5 1/2	CV	1262999	3	16.2	DM	40	9	15.875	5/8	G30	20	6	15.875	5/8	G20	4	15.875	5/8	G20	-	-	-	-	-	-	-	-	-	-
140	5 1/2	DC	1049141	3	16.4	DM	35	9	15.875	5/8	G20	-	-	-	-	-	4	15.875	5/8	G20	3	15.875	5/8	G20	-	-	-	-	-	
140	5 1/2	FF	1100652	3	16.4	DM	35	9	15.875	5/8	G30	-	-	-	-	-	9	15.875	5/8	G20	-	-	-	-	-	-	-	-	-	
152	6	FF	1100661	3	17.2	DM	35	9	18	-	G30	-	-	-	-	-	9	15.875	5/8	G20	-	-	-	-	-	-	-	-	-	

Robit[®]
www.robitegroup.com

sales@robitegroup.com
CONVENTIONAL DRILL BIT RANGE

DRILL BIT RANGE

QL6

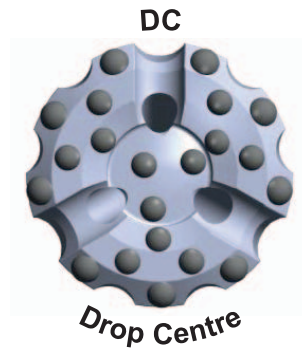
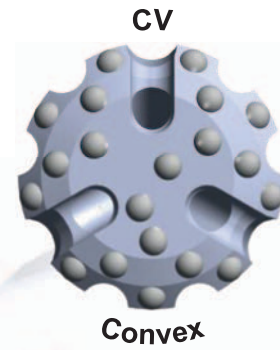
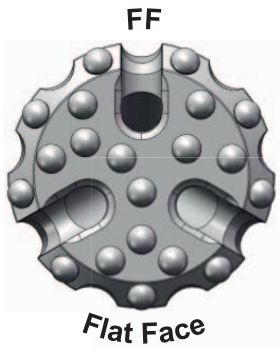

HEAD DIAMETER (mm)	HEAD DIAMETER (inch)	FACE DESIGN	ITEM CODE	NUMBER OF PORTS	WEIGHT (kg)	BUTTON PROFILE	GAUGE ANGLE (°)	GAUGE CARBIDE QTY.	GAUGE CARBIDE DIA. (mm)	GAUGE CARBIDE DIA. (inch)	GAUGE CARBIDE GRADE	GAUGE 2 ANGLE (°)	GAUGE 2 CARBIDE QTY.	GAUGE 2 CARBIDE DIA. (mm)	GAUGE 2 CARBIDE DIA. (inch)	GAUGE 2 CARBIDE GRADE	FACE CARBIDE QTY.	FACE CARBIDE DIA. (mm)	FACE CARBIDE DIA. (inch)	FACE CARBIDE GRADE	CENTER CARBIDE QTY.	CENTER CARBIDE DIA. (mm)	CENTER CARBIDE DIA. (inch)	CENTER CARBIDE GRADE	CONE ANGLE (°)	CONE CARBIDE QTY.	CONE CARBIDE DIA. (mm)	CONE CARBIDE DIA. (inch)	CONE CARBIDE GRADE
165	6 1/2	CC	1100671	3	23.3	DM	35	9	18	-	G20	-	-	-	-	-	6	15.875	5/8	G20	-	-	-	-	-15	6	15.875	5/8	G20
165	6 1/2	CC	1053268	3	23.1	DM	35	9	18	-	G30	-	-	-	-	-	6	15.875	5/8	G20	-	-	-	-	-15	6	15.875	5/8	G20
165	6 1/2	DC	1061419	3	21.3	DM	35	9	18	-	G20	-	-	-	-	-	6	15.875	5/8	G20	3	15.875	5/8	G20	-20	3	15.875	5/8	G20
165	6 1/2	FF	1000810	3	23.2	DM	35	9	18	-	G20	-	-	-	-	-	11	18	-	G20	-	-	-	-	-	-	-	-	-
165	6 1/2	FF	1100665	3	22.9	DM	35	9	18	-	G30	-	-	-	-	-	9	15.875	5/8	G20	-	-	-	-	-	-	-	-	-
171	6 3/4	CV	1262391	3	25	DM	40	9	18	-	G40*	20	6	18	-	G30	6	18	-	G30	-	-	-	-	-	-	-	-	-
171	6 3/4	CC	1100672	3	24	DM	35	9	18	-	G30	-	-	-	-	-	6	15.875	5/8	G20	-	-	-	-	-15	6	15.875	5/8	G20
171	6 3/4	FF	1259809	3	23.7	DM	35	9	18	-	G20	-	-	-	-	-	11	18	-	G20	-	-	-	-	-	-	-	-	-

Robit[®]
www.robitegroup.com

sales@robitegroup.com
CONVENTIONAL DRILL BIT RANGE

DRILL BIT RANGE

D75

CC

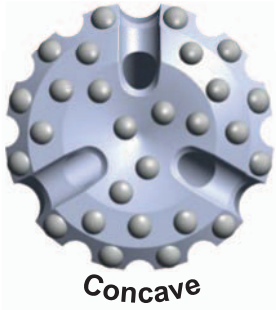

DC



HEAD DIAMETER (mm)	HEAD DIAMETER (inch)	FACE DESIGN	ITEM CODE	NUMBER OF PORTS	WEIGHT (kg)	BUTTON PROFILE	GAUGE ANGLE (°)	GAUGE CARBIDE QTY.	GAUGE CARBIDE DIA. (mm)	GAUGE CARBIDE DIA. (inch)	GAUGE CARBIDE GRADE	GAUGE 2 ANGLE (°)	GAUGE 2 CARBIDE QTY.	GAUGE 2 CARBIDE DIA. (mm)	GAUGE 2 CARBIDE DIA. (inch)	GAUGE 2 CARBIDE GRADE	FACE CARBIDE QTY.	FACE CARBIDE DIA. (mm)	FACE CARBIDE DIA. (inch)	FACE CARBIDE GRADE	CENTER CARBIDE QTY.	CENTER CARBIDE DIA. (mm)	CENTER CARBIDE DIA. (inch)	CENTER CARBIDE GRADE	CONE ANGLE (°)	CONE CARBIDE QTY.	CONE CARBIDE DIA. (mm)	CONE CARBIDE DIA. (inch)	CONE CARBIDE GRADE
203	8	DC	1030890	3	42.2	DM	35	12	19	3/4	G30	-	-	-	-	-	12	18	-	G20	4	18	-	G20	-	-	-	-	-
203	8	CC	1280149	3	42	DM	35	12	19	3/4	G30	-	-	-	-	-	9	18	-	G30	-	-	-	-	-15	6	18	-	G20
229	9	DC	1255336	3	45.9	DM	35	12	19	3/4	G30	-	-	-	-	-	15	19	3/4	G30	5	18	-	G20	-	-	-	-	-

Robit[®]
www.robitegroup.com

sales@robitegroup.com
CONVENTIONAL DRILL BIT RANGE

DRILL BIT RANGE

QL8



HEAD DIAMETER (mm)	HEAD DIAMETER (inch)	FACE DESIGN	ITEM CODE	NUMBER OF PORTS	WEIGHT (kg)	BUTTON PROFILE	GAUGE ANGLE (°)	GAUGE CARBIDE QTY.	GAUGE CARBIDE DIA. (mm)	GAUGE CARBIDE DIA. (inch)	GAUGE CARBIDE GRADE	GAUGE 2 ANGLE (°)	GAUGE 2 CARBIDE QTY.	GAUGE 2 CARBIDE DIA. (mm)	GAUGE 2 CARBIDE DIA. (inch)	GAUGE 2 CARBIDE GRADE	FACE CARBIDE QTY.	FACE CARBIDE DIA. (mm)	FACE CARBIDE DIA. (inch)	FACE CARBIDE GRADE	CENTER CARBIDE QTY.	CENTER CARBIDE DIA. (mm)	CENTER CARBIDE DIA. (inch)	CENTER CARBIDE GRADE	CONE ANGLE (°)	CONE CARBIDE QTY.	CONE CARBIDE DIA. (mm)	CONE CARBIDE DIA. (inch)	CONE CARBIDE GRADE	
229	9	FF	1240999	3	52.3	DM*	35	12	19	3/4	G20	-	-	-	-	-	17	19	3/4	G20	-	-	-	-	-	-	-	-	-	-
229	9	FF	1100748	3	52.4	DM	35	12	19	3/4	G30	-	-	-	-	-	17	19	3/4	G20	-	-	-	-	-	-	-	-	-	

Robit[®]
www.robitegroup.com

sales@robitegroup.com
CONVENTIONAL DRILL BIT RANGE

AIR CORE DRILL BIT ASSEMBLY

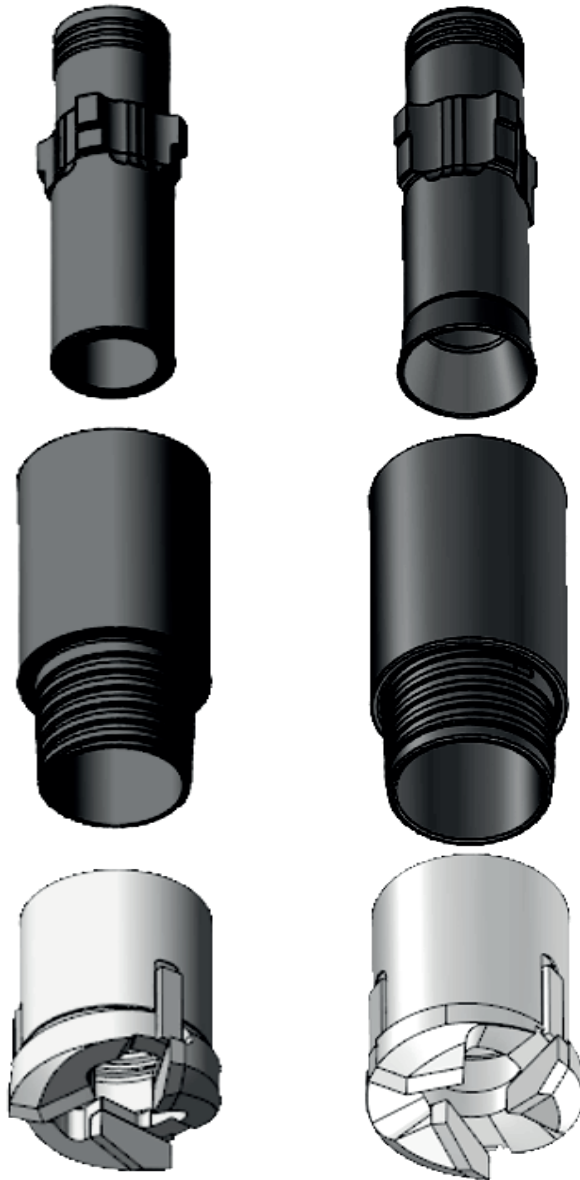

Face
Discharge

Vacuum

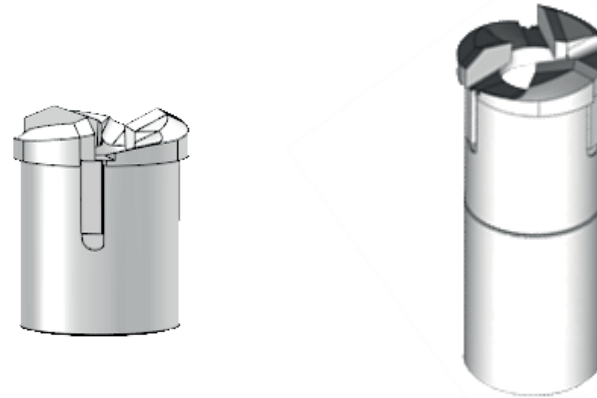

Aircore Drill Bit Range

Part No.	Description	Bit Size	Rod Size
Vacuum Aircore Bit			
1255734	BIT; 3 BLADE; 3IN; VACUUM AIR CORE	85mm	
1255729	SUB; BIT; 3IN; VACUUM AIR CORE TS/NQ		3"
1255730	INNER TUBE; BIT SUB; 3IN; VACUUM AIR CORE		
Discharge Aircore Bit			
1256049	BIT; 3 BLADE; 3IN; FACE DISCHARGE AIR CORE	85mm	
1256047	SUB; BIT; 3IN; FACE DISCHARGE AIR CORE TS/LW		3"
1243701	INNER TUBE AIR CORE BIT 3IN FACE DISCHARGE		

HAMMER ASSEMBLY

DR38 3 1/2" REMET



1043652 DR38 3 1/2" REMET HAMMER ASSEMBLY

1	1000891	Circlip Internal
2	1106899	Adaptor Screen 3 1/2" Remet
3	1044415	Top Sub 3 1/2" Remet
4	1044411	Check Valve Plunger
5	1106900	Check Valve Spring
6	1043640	Adaptor Tube
7	1044418	Steel Make Up Ring
8	1044419	Make Up Ring
9	1044421	Distributor
10	1043641	Sample Tube Venturi
11	1044422	Sample Tube Mount
12	1044423	Inner Cylinder
13	1031969	Piston
14	1043643	Cylinder
15	1107024	Piston Retaining Ring
16	1044424	Drive Sub Bush
17	1042513	Bit Retaining Ring
18	1043646	Gauge Sleeve 3 15/16"
19	1043650	Drive Sub

Specifications

Bit Shank	DR38
Bit Range	4" - 102mm - to 4 1/2" - 114mm
Top Sub Thread	3 1/2" Remet
Spanner Flat	3.16" - 80.5mm A/F x 1.96" - 50mm
Overall Length S/S	35.03" - 890mm
Weight (less bit)	65 lbs. - 29.5kg
Cylinder O.D.	3.74" - 95mm
Oil Consumption	1.5 - 2.0 litres per hour

1050386	O Ring Kit
1050385	Make Up Kit
1256709	Sample Tube Std

Air Pressure

PSI	Air Consumption		
	bar	CFM	m ³ /min
150	10.3	260	7.3
220	15.3	320	9.0
250	17.2	377	10.7
300	20.7	459	13
350	24.1	544	15.4
400	27.5	627	17.8

Robit[®]
www.robitegroup.com

sales@robitegroup.com

DR38 3.5 REMET ASSY 1043652

HAMMER ASSEMBLY

DR43 3½" REMET

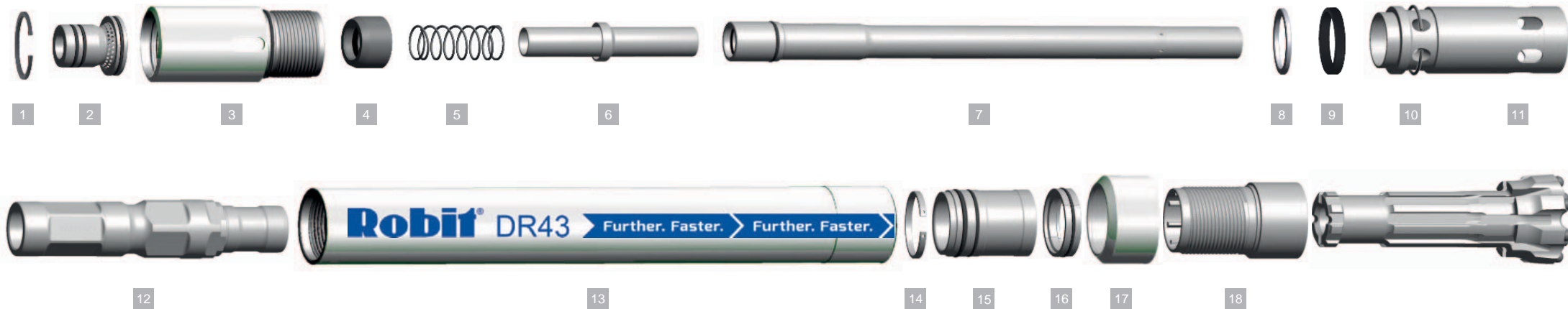

1270069 DR43 3½" REMET HAMMER ASSEMBLY

1	1000892	Circlip Internal
2	1270077	Adaptor Screen 3 ½" Remet
3	1270073	Top Sub 3 ½" Remet
4	1270079	Check Valve Plunger
5	1270080	Check Valve Spring
6	1270078	Adaptor Tube
7	1270086	Sample Tube Venturi
8	1270083	Steel Make Up Ring
9	1270082	Make Up Ring
10	1270089	Inner Cylinder Retaining Ring
11	1270088	Inner Cylinder
12	1270090	Piston
13	1270087	Cylinder
14	1270091	Piston Retaining Ring
15	1270092	Drive Sub Bush
16	1270093	Bit Retaining Ring
17	1270105	Gauge Sleeve 4 13/16"
18	1270094	Drive Sub

Specifications

Bit Shank	DR43
Bit Range	4 ½" - 114mm to 5 ½" - 130mm
Top Sub Thread	3 ½" Remet
Spanner Flat	N/A
Overall Length S/S	43.5" - 1105mm
Weight (less bit)	98.8 lbs. - 44.8kg
Cylinder O.D.	4.21" - 107mm
Oil Consumption	2 - 3 litres per hour
1270108	O Ring Kit
1270109	Make Up Kit
1270085	Sample Tube Std

Air Pressure

Air Pressure		Air Consumption	
PSI	bar	CFM	m ³ /min
150	10.3	300	8.4
200	13.8	340	9.5
250	17.2	415	11.7
300	20.7	504	14.2
350	24.1	585	16.5
400	27.5	670	18.8

Robit[®]
www.robitegroup.com

sales@robitegroup.com

DR43 3.5 REMET ASSY 1270069

HAMMER ASSEMBLY

DR43 4" REMET

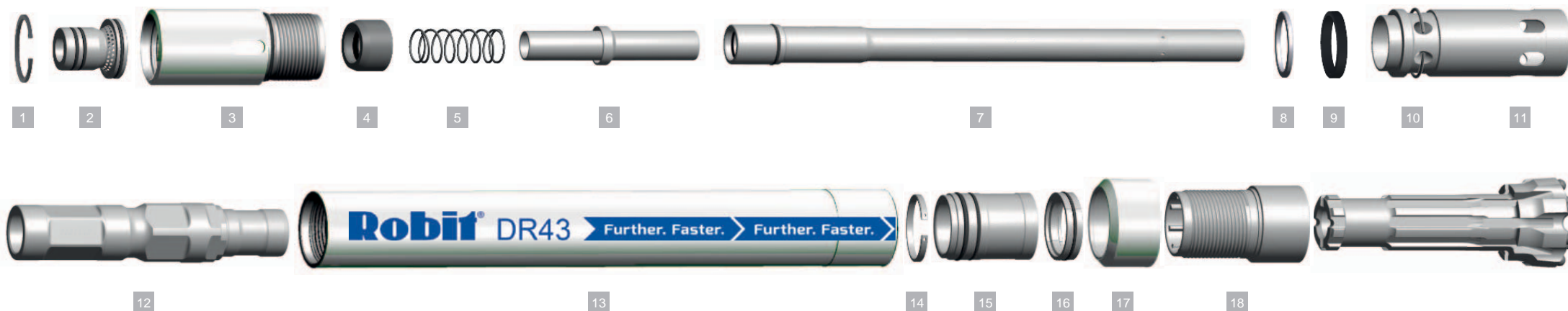

1270065 DR43 4" REMET HAMMER ASSEMBLY

1	1000895	Circlip Internal
2	1270075	Adaptor Screen 4" Remet
3	1270071	Top Sub 4" Remet
4	1270079	Check Valve Plunger
5	1270080	Check Valve Spring
6	1270078	Adaptor Tube
7	1270086	Sample Tube Venturi
8	1270083	Steel Make Up Ring
9	1270082	Make Up Ring
10	1270089	Inner Cylinder Retaining Ring
11	1270088	Inner Cylinder
12	1270090	Piston
13	1270087	Cylinder
14	1270091	Piston Retaining Ring
15	1270092	Drive Sub Bush
16	1270093	Bit Retaining Ring
17	1270105	Gauge Sleeve 4 13/16"
18	1270094	Drive Sub

Specifications

Bit Shank	DR43
Bit Range	4 1/2" - 114mm to 5 1/8" - 130mm
Top Sub Thread	4" Remet
Spanner Flat	N/A
Overall Length S/S	43.5" - 1105mm
Weight (less bit)	98.8 lbs. - 44.8kg
Cylinder O.D.	4.21" - 107mm
Oil Consumption	2 - 3 litres per hour

1270108	O Ring Kit
1270109	Make Up Kit
1270085	Sample Tube Std

Air Pressure

PSI	bar	CFM	m ³ /min
150	10.3	300	8.4
200	13.8	340	9.5
250	17.2	415	11.7
300	20.7	504	14.2
350	24.1	585	16.5
400	27.5	670	18.8

Air Consumption

Robit[®]
www.robitegroup.com

sales@robitegroup.com

DR43 4 REMET ASSY 1270065

HAMMER ASSEMBLY

DR44 4" REMET

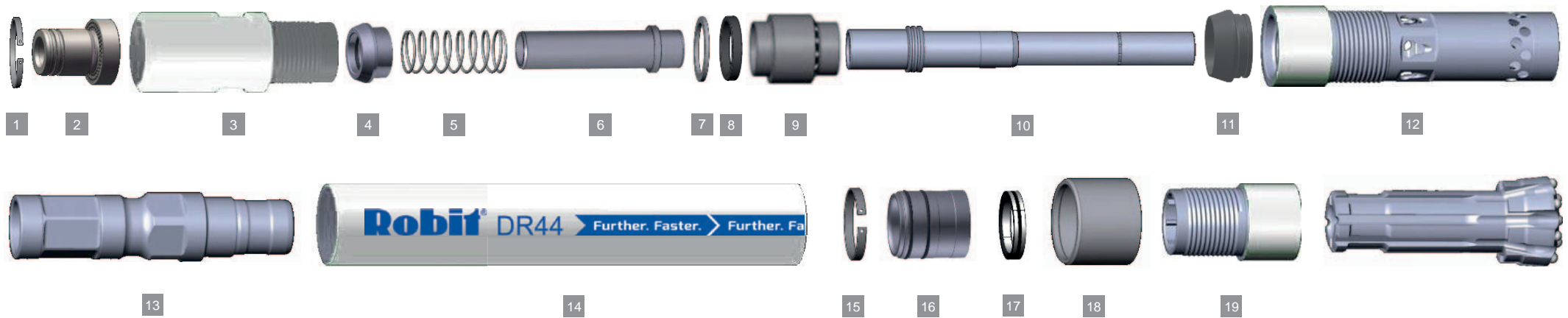

1059546 DR44 4" REMET HAMMER ASSEMBLY

1	1000895	Circlip Internal
2	1107035	Adaptor Screen 4" Remet
3	1107041	Top Sub 4" Remet
4	1046940	Check Valve Plunger
5	1046941	Check Valve Spring
6	1043770	Adaptor Tube
7	1046943	Steel Make Up Ring
8	1046942	Make Up Ring
9	1066177	Distributor
10	1046945	Sample Tube Venturi
11	1107120	Sample Tube Mount
12	1046946	Inner Cylinder 104.9mm A/F
13	1046947	Piston
14	1046948	Cylinder
15	1061501	Piston Retaining Ring
16	1046950	Drive Sub Bush
17	1046951	Bit Retaining Ring
18	1046958	Gauge Sleeve 5 3/16"
19	1043771	Drive Sub

Specifications

Bit Shank	DR44
Bit Range	5 ¼" - 133mm to 5 ½" - 140mm
Top Sub Thread	4" Remet
Spanner Flat	3.7" - 94mm A/F x 1.96" - 50mm
Overall Length S/S	47.6" - 1210mm
Weight (less bit)	154 lbs. - 70kg
Cylinder O.D.	4.76" - 121mm
Oil Consumption	2 - 3 litres per hour

1071679	O Ring Kit
1059550	Make Up Kit
1046944	Sample Tube Std

Air Pressure

Air Pressure		Air Consumption	
PSI	bar	CFM	m ³ /min
250	17.2	504	13.6
300	20.7	614	16.6
350	24.1	708	19.1
400	27.5	808	21.8
450	31	903	24.2
500	34.5	987	26.6

Robit[®]
www.robitegroup.com

sales@robitegroup.com

DR44 4 REMET ASSY 1059546

HAMMER ASSEMBLY

DR44 4½" REMET

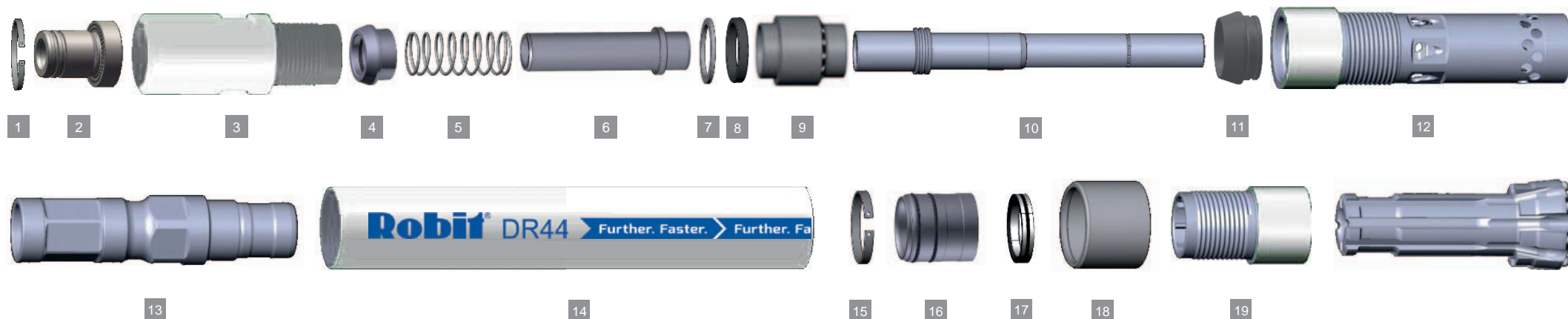

1063065 DR44 4½" REMET HAMMER ASSEMBLY

1	1000896	Circlip Internal
2	1084159	Adaptor Screen 4 ½" Remet
3	1046939	Top Sub 4 ½" Remet
4	1046940	Check Valve Plunger
5	1046941	Check Valve Spring
6	1043770	Adaptor Tube
7	1046943	Steel Make Up Ring
8	1046942	Make Up Ring
9	1066177	Distributor
10	1046945	Sample Tube Venturi
11	1107120	Sample Tube Mount
12	1046946	Inner Cylinder 104.9mm A/F
13	1046947	Piston
14	1046948	Cylinder
15	1061501	Piston Retaining Ring
16	1046950	Drive Sub Bush
17	1046951	Bit Retaining Ring
18	1046958	Gauge Sleeve 5 3/16"
19	1043771	Drive Sub

Specifications

Bit Shank	DR44
Bit Range	5 ¼" - 133mm to 5 ½" - 140mm
Top Sub Thread	4 ½" Remet
Spanner Flat	3.7" - 94mm A/F x 1.96" - 50mm
Overall Length S/S	47.6" - 1210mm
Weight (less bit)	154 lbs. - 70kg
Cylinder O.D.	4.76" - 121mm
Oil Consumption	2 - 3 litres per hour

1071679	O Ring Kit
1059550	Make Up Kit
1046944	Sample Tube Std

Air Pressure

PSI	bar	CFM	m³/min
250	17.2	504	13.6
300	20.7	614	16.6
350	24.1	708	19.1
400	27.5	808	21.8
450	31	903	24.2
500	34.5	987	26.6

Air Consumption

Robit[®]
www.robitegroup.com

sales@robitegroup.com

DR44 4.5 REMET ASSY 1063065

HAMMER ASSEMBLY

DR53 4½" REMET

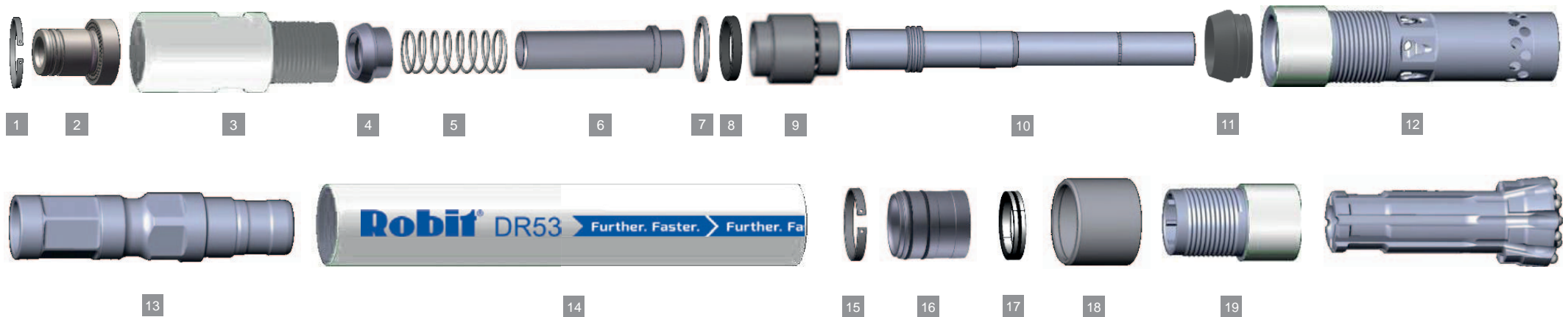

1108034 DR53 4½" REMET HAMMER ASSEMBLY

1	1000896	Circlip Internal
2	1084159	Adaptor Screen 4 ½" Remet
3	1107182	Top Sub 4 ½" Remet
4	1046940	Check Valve Plunger
5	1046941	Check Valve Spring
6	1043770	Adaptor Tube
7	1046943	Steel Make Up Ring
8	1046942	Make Up Ring
9	1066177	Distributor
10	1107637	Sample Tube Venturi
11	1107183	Sample Tube Mount
12	1107185	Inner Cylinder 101.6mm A/F
13	1107186	Piston
14	1258073	Cylinder
15	1107191	Piston Retaining Ring
16	1107192	Drive Sub Bush
17	1118005	Bit Retaining Ring
18	1107221	Gauge Sleeve 5 7/16"
19	1107227	Drive Sub

Specifications

Bit Shank	DR53
Bit Range	5 3/8" - 137mm to 5 5/8" - 143mm
Top Sub Thread	4 ½" Remet
Spanner Flat	3.7" - 95mm A/F x 1.96" - 50mm
Overall Length S/S	48" - 1226mm
Weight (less bit)	176 lbs. - 80kg
Cylinder O.D.	4.76" - 121mm
Oil Consumption	2 - 3 litres per hour

1103213	O Ring Kit
1103211	Make Up Kit
1118004	Sample Tube Std

Air Pressure

Air Pressure		Air Consumption	
PSI	bar	CFM	m ³ /min
250	17.2	550	16.1
300	24.1	660	19.3
400	27.5	750	21.9
450	31.0	925	27.0
500	34.5	1030	30.1

Robit[®]
www.robitegroup.com

sales@robitegroup.com
DR53 4.5 REMET ASSY 1108034

HAMMER ASSEMBLY

DR53 4½" REMET RETENTION

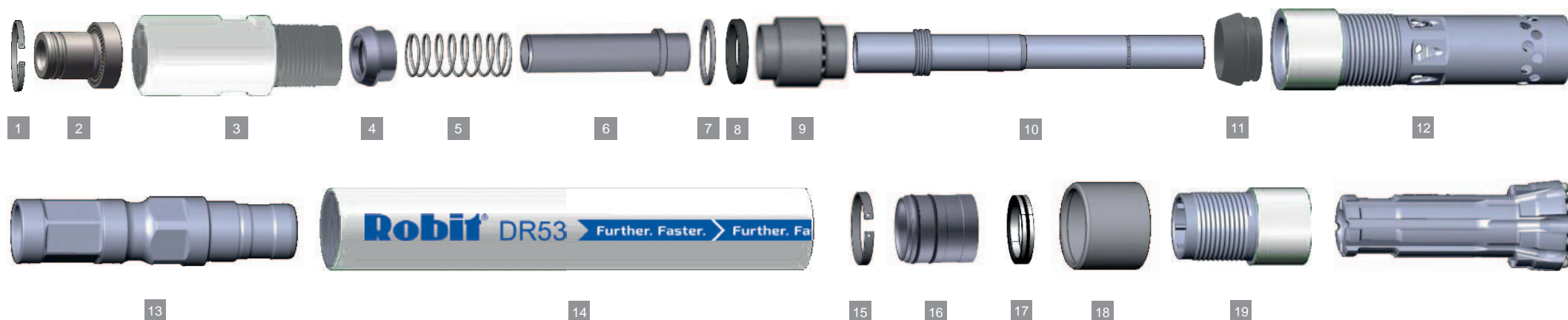

1252172 DR53 4½" REMET RETENTION HAMMER ASSY

1	1000896	Circlip Internal
2	1084159	Adaptor Screen 4 ½" Remet
3	1107182	Top Sub 4 ½" Remet
4	1046940	Check Valve Plunger
5	1046941	Check Valve Spring
6	1043770	Adaptor Tube
7	1046943	Steel Make Up Ring
8	1046942	Make Up Ring
9	1066177	Distributor
10	1107637	Sample Tube Venturi
11	1107183	Sample Tube Mount
12	1107185	Inner Cylinder 101.6mm A/F
13	1107186	Piston
14	1258073	Cylinder
15	1107191	Piston Retaining Ring
16	1107192	Drive Sub Bush
17	1118005	Bit Retaining Ring
18	1216716	Gauge Sleeve 5 7/16" Retention
19	1216711	Drive Sub Retention

Specifications

Bit Shank	DR53
Bit Range	5 3/8" - 137mm to 5 5/8" - 143mm
Top Sub Thread	4 ½" Remet
Spanner Flat	3.7" - 95mm A/F x 1.96" - 50mm
Overall Length S/S	48" - 1226mm
Weight (less bit)	176 lbs. - 80kg
Cylinder O.D.	4.76" - 121mm
Oil Consumption	2 - 3 litres per hour

1103213	O Ring Kit
1103211	Make Up Kit
1118004	Sample Tube Std

Air Pressure

PSI	bar	CFM	m³/min
250	17.2	550	16.1
300	24.1	660	19.3
400	27.5	750	21.9
450	31.0	925	27.0
500	34.5	1030	30.1

Air Consumption

Robit[®]
www.robitegroup.com

sales@robitegroup.com

DR53 4.5 REMET RETENTION ASSY 1252172

HAMMER ASSEMBLY

DR53 4½" METZKE

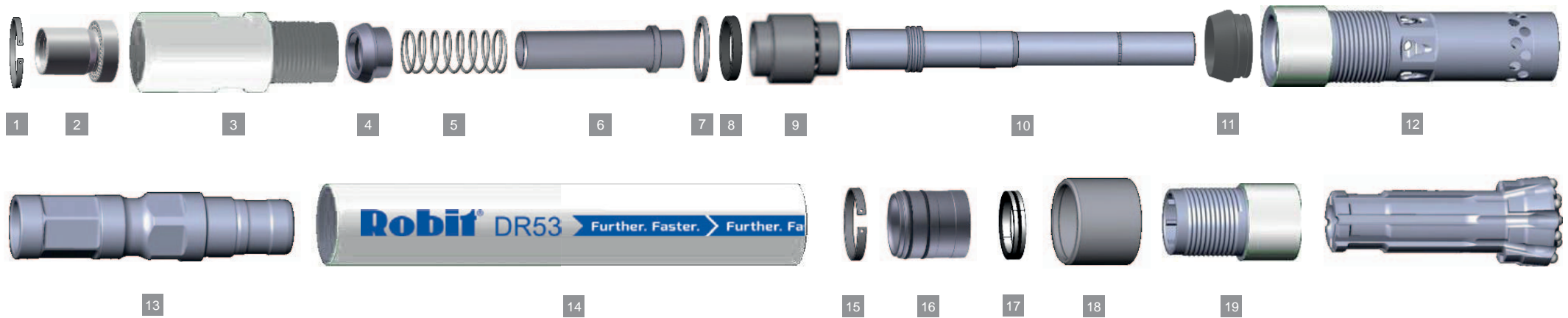

1108033 DR53 4½" METZKE HAMMER ASSEMBLY

1	1000896	Circlip Internal
2	1107736	Adaptor Screen 4 ½" Metzke
3	1107181	Top Sub 4 ½" Metzke
4	1046940	Check Valve Plunger
5	1046941	Check Valve Spring
6	1043770	Adaptor Tube
7	1046943	Steel Make Up Ring
8	1046942	Make Up Ring
9	1066177	Distributor
10	1107637	Sample Tube Venturi
11	1107183	Sample Tube Mount
12	1107184	Inner Cylinder
13	1107186	Piston
14	1258073	Cylinder
15	1107191	Piston Retaining Ring
16	1107192	Drive Sub Bush
17	1118005	Bit Retaining Ring
18	1107221	Gauge Sleeve 5 7/16"
19	1107227	Drive Sub

Specifications

Bit Shank	DR53
Bit Range	5 3/8" - 137mm to 5 5/8" - 143mm
Top Sub Thread	4 ½" Metzke
Spanner Flat	3.7" - 95mm A/F x 1.96" - 50mm
Overall Length S/S	48" - 1226mm
Weight (less bit)	176 lbs. - 80kg
Cylinder O.D.	4.76" - 121mm
Oil Consumption	2 - 3 litres per hour

1103213	O Ring Kit
1103211	Make Up Kit
1118004	Sample Tube Std

Air Pressure

Air Pressure		Air Consumption	
PSI	bar	CFM	m³/min
250	17.2	550	16.1
300	24.1	660	19.3
400	27.5	750	21.9
450	31.0	925	27.0
500	34.5	1030	30.1

Robit[®]
www.robitegroup.com

sales@robitegroup.com

DR53 4.5 METZKE ASSY 1108033

HAMMER ASSEMBLY

DR53 4 1/2" METZKE HEAVY DUTY

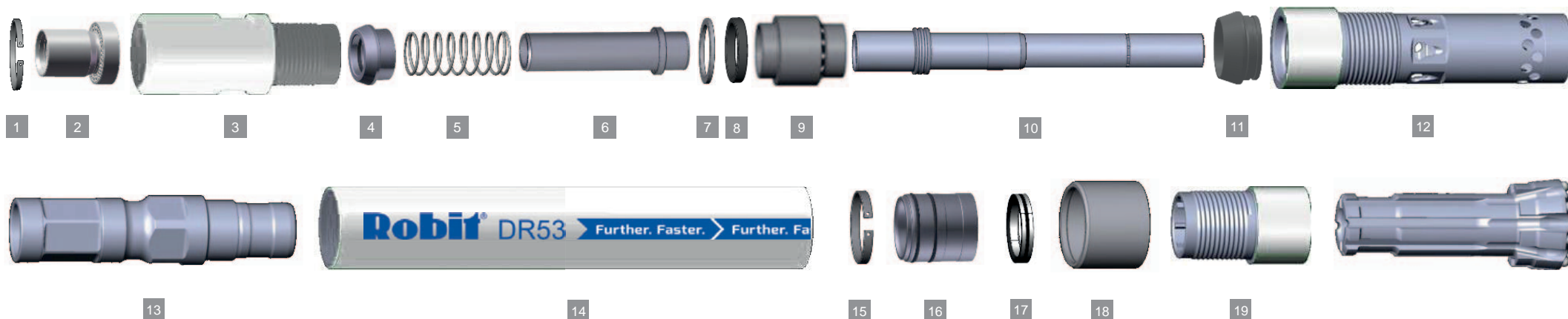

1220145 DR53 4 1/2" METZKE HEAVY DUTY ASSEMBLY

1	1000896	Circlip Internal
2	1107736	Adaptor Screen 4 1/2" Metzke
3	1107181	Top Sub 4 1/2" Metzke
4	1046940	Check Valve Plunger
5	1046941	Check Valve Spring
6	1043770	Adaptor Tube
7	1046943	Steel Make Up Ring
8	1046942	Make Up Ring
9	1066177	Distributor
10	1107637	Sample Tube Venturi
11	1107183	Sample Tube Mount
12	1107184	Inner Cylinder
13	1107186	Piston
14	1216718	Cylinder HD
15	1107191	Piston Retaining Ring
16	1107192	Drive Sub Bush
17	1118005	Bit Retaining Ring
18	1220142	Gauge Sleeve 5 7/16" HD
19	1216305	Drive Sub SF

Specifications

Bit Shank	DR53
Bit Range	5 3/8" - 137mm to 5 5/8" - 143mm
Top Sub Thread	4 1/2" Metzke
Spanner Flat	3.7" - 95mm A/F x 1.96" - 50mm
Overall Length S/S	48" - 1226mm
Weight (less bit)	176 lbs. - 80kg
Cylinder O.D.	4.96" - 126mm
Oil Consumption	2 - 3 litres per hour

1103213	O Ring Kit
1103211	Make Up Kit
1118004	Sample Tube Std

Air Pressure

PSI	Air Consumption		
	bar	CFM	m ³ /min
250	17.2	550	16.1
300	24.1	660	19.3
400	27.5	750	21.9
450	31.0	925	27.0
500	34.5	1030	30.1

Robit[®]
www.robitegroup.com

sales@robitegroup.com

DR53 4.5 METZKE HEAVY DUTY ASSY 1220145

HAMMER ASSEMBLY

DR55 4½" REMET

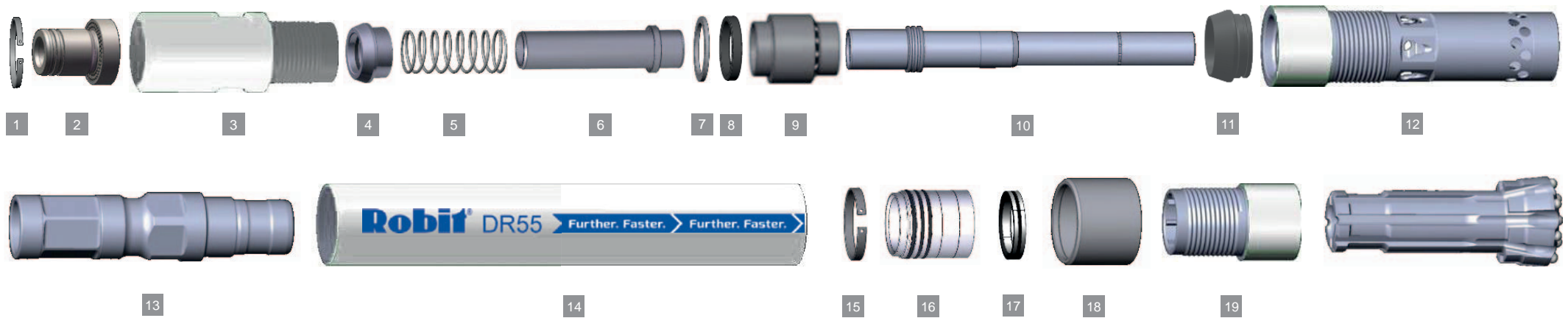

1051842 DR55 4½" REMET HAMMER ASSEMBLY

1	1046842	Circlip Internal
2	1048119	Adaptor Screen 4 ½" Remet
3	1048188	Top Sub 4 ½" Remet
4	1048189	Check Valve Plunger
5	1009557	Check Valve Spring
6	1048192	Adaptor Tube
7	1009562	Steel Make Up Ring
8	1010627	Make Up Ring
9	1048194	Distributor
10	1048195	Sample Tube Venturi
11	1048196	Sample Tube Mount
12	1048197	Inner Cylinder
13	1107238	Piston
14	1248977	Cylinder
15	1044582	Piston Retaining Ring
16	1009572	Drive Sub Bush
17	1009573	Bit Retaining Ring
18	1051774	Gauge Sleeve 5 7/16"
19	1051849	Drive Sub

Specifications

Bit Shank	DR55
Bit Range	5 3/8" - 137mm to 5 3/4" - 146mm
Top Sub Thread	4 ½" Remet
Spanner Flat	4.09" - 104mm A/F x 1.96" - 50mm
Overall Length S/S	49.3" - 1252mm
Weight (less bit)	189 lbs - 86kg
Cylinder O.D.	5.1" - 130mm
Oil Consumption	2 - 3 litres per hour

1048201	O Ring Kit
1048200	Make Up Kit
1113851	Sample Tube Std

Air Pressure

Air Pressure		Air Consumption	
PSI	bar	CFM	m ³ /min
250	17.2	577	16.3
350	24.1	787	22.3
450	31	971	27.5
550	37.9	1156	32.7
650	44.8	1445	40.9
750	51.7	1806	51.1

Robit[®]
www.robitegroup.com

sales@robitegroup.com

DR55 4.5 REMET ASSY 1051842

HAMMER ASSEMBLY

DR55 4½" REMET

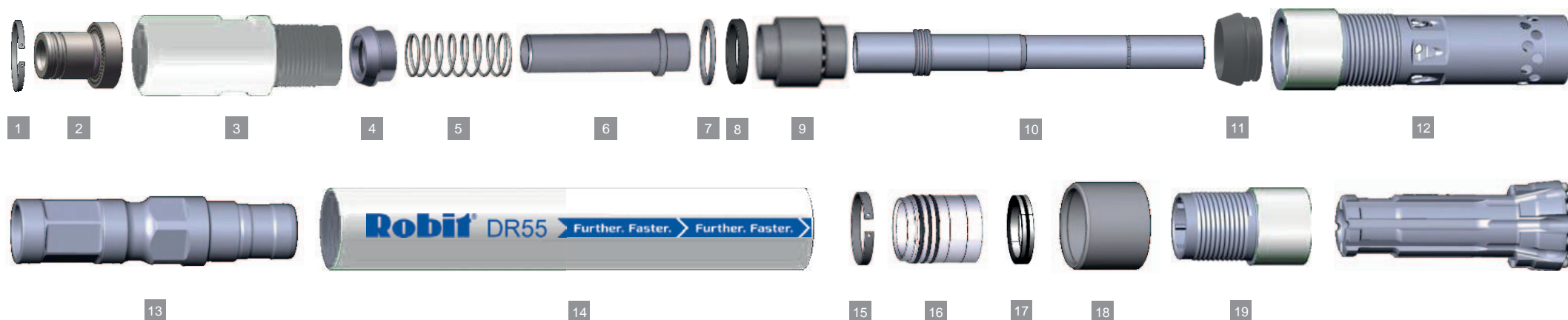

1204583 DR55 4½" REMET HAMMER ASSEMBLY

1	1046842	Circlip Internal
2	1048119	Adaptor Screen 4 ½" Remet
3	1048188	Top Sub 4 ½" Remet
4	1048189	Check Valve Plunger
5	1009557	Check Valve Spring
6	1048192	Adaptor Tube
7	1009562	Steel Make Up Ring
8	1010627	Make Up Ring
9	1048194	Distributor
10	1048195	Sample Tube Venturi
11	1048196	Sample Tube Mount
12	1107237	Inner Cylinder C/W Spanner Flats
13	1107238	Piston
14	1248977	Cylinder
15	1044582	Piston Retaining Ring
16	1009572	Drive Sub Bush
17	1009573	Bit Retaining Ring
18	1051774	Gauge Sleeve 5 7/16"
19	1051849	Drive Sub

Specifications

Bit Shank	DR55
Bit Range	5 3/8" - 137mm to 5 3/4" - 146mm
Top Sub Thread	4 ½" Remet
Spanner Flat	4.09" - 104mm A/F x 1.96" - 50mm
Overall Length S/S	49.3" - 1252mm
Weight (less bit)	189 lbs - 86kg
Cylinder O.D.	5.1" - 130mm
Oil Consumption	2 - 3 litres per hour
	1048201 O Ring Kit
	1048200 Make Up Kit
	1113851 Sample Tube Std

Air Pressure

Air Consumption

PSI	bar	CFM	m ³ /min
250	17.2	577	16.3
350	24.1	787	22.3
450	31	971	27.5
550	37.9	1156	32.7
650	44.8	1445	40.9
750	51.7	1806	51.1

Robit[®]
www.robitegroup.com

sales@robitegroup.com

DR55 4.5 REMET INNER CYL WITH FLATS ASSY 1204583

HAMMER ASSEMBLY

DR55 4½" REMET RETENTION

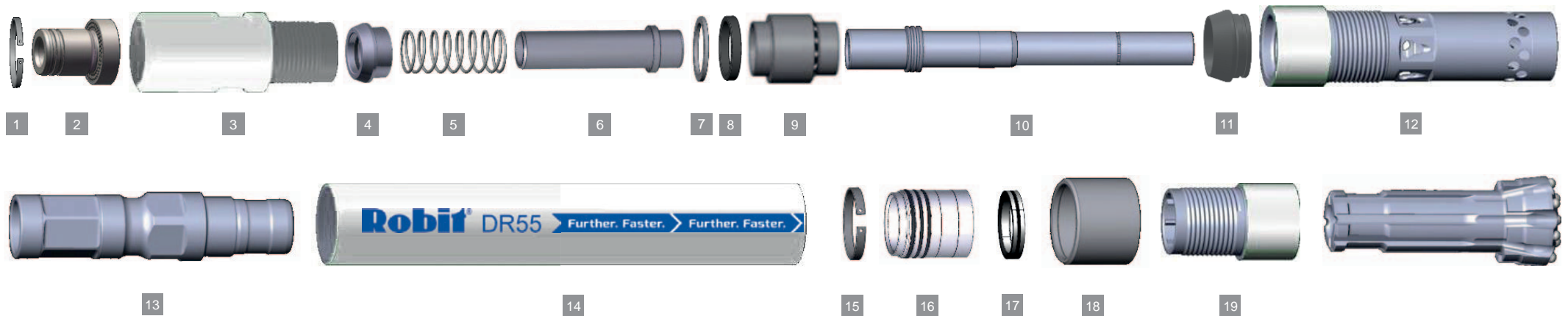

1051843 DR55 4½" REMET RETENTION HAMMER ASSY

1	1046842	Circlip Internal
2	1048119	Adaptor Screen 4 ½" Remet
3	1048188	Top Sub 4 ½" Remet
4	1048189	Check Valve Plunger
5	1009557	Check Valve Spring
6	1048192	Adaptor Tube
7	1009562	Steel Make Up Ring
8	1010627	Make Up Ring
9	1048194	Distributor
10	1048195	Sample Tube Venturi
11	1048196	Sample Tube Mount
12	1048197	Inner Cylinder
13	1107238	Piston
14	1248977	Cylinder
15	1044582	Piston Retaining Ring
16	1009572	Drive Sub Bush
17	1009573	Bit Retaining Ring
18	1051761	Gauge Sleeve 5 7/16" Retention
19	1046868	Drive Sub Retention

Specifications

Bit Shank	DR55
Bit Range	5 3/8" - 137mm to 5 3/4" - 146mm
Top Sub Thread	4 ½" Remet
Spanner Flat	4.09" - 104mm A/F x 1.96" - 50mm
Overall Length S/S	49.3" - 1252mm
Weight (less bit)	189 lbs - 86kg
Cylinder O.D.	5.1" - 130mm
Oil Consumption	2 - 3 litres per hour
	1048201 O Ring Kit
	1048200 Make Up Kit
	1113851 Sample Tube Std

Air Pressure

PSI	bar	CFM	m³/min
250	17.2	577	16.3
350	24.1	787	22.3
450	31	971	27.5
550	37.9	1156	32.7
650	44.8	1445	40.9
750	51.7	1806	51.1

Robit[®]
www.robitegroup.com

sales@robitegroup.com

DR55 4.5 REMET RETENTION ASSY 1051843

HAMMER ASSEMBLY

DR55 4½" METZKE

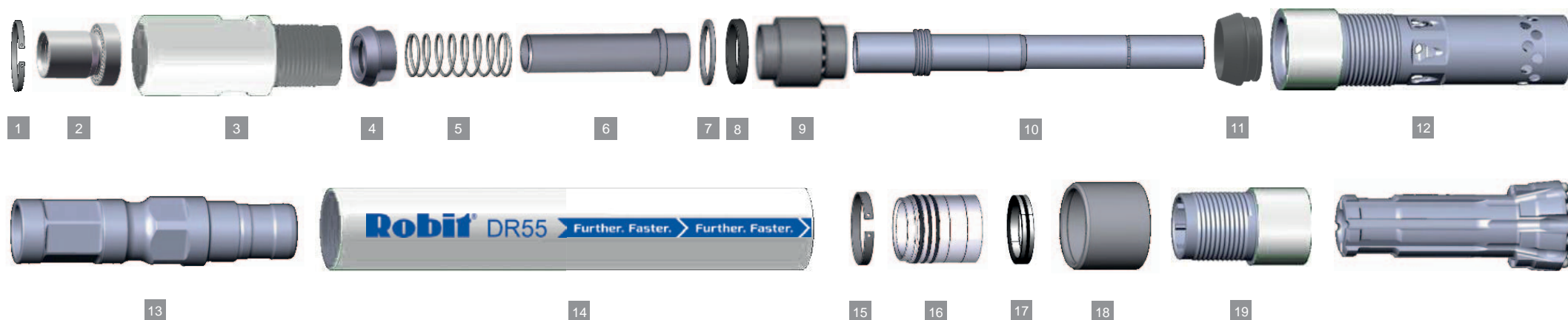

1108035 DR55 4½" METZKE HAMMER ASSEMBLY

1	1107229	Circlip Internal
2	1059984	Adaptor Screen 4 ½" Metzke
3	1107234	Top Sub 4 ½" Metzke
4	1048189	Check Valve Plunger
5	1009557	Check Valve Spring
6	1048192	Adaptor Tube
7	1009562	Steel Make Up Ring
8	1010627	Make Up Ring
9	1048194	Distributor
10	1048195	Sample Tube Venturi
11	1048196	Sample Tube Mount
12	1048197	Inner Cylinder
13	1107238	Piston
14	1248977	Cylinder
15	1044582	Piston Retaining Ring
16	1009572	Drive Sub Bush
17	1009573	Bit Retaining Ring
18	1051774	Gauge Sleeve 5 7/16"
19	1051849	Drive Sub

Specifications

Bit Shank	DR55
Bit Range	5 3/8" - 137mm to 5 3/4" - 146mm
Top Sub Thread	4 ½" Metzke
Spanner Flat	4.09" - 104mm A/F x 1.96" - 50mm
Overall Length S/S	49.3" - 1252mm
Weight (less bit)	189 lbs - 86kg
Cylinder O.D.	5.1" - 130mm
Oil Consumption	2 - 3 litres per hour

1048201	O Ring Kit
1048200	Make Up Kit
1113851	Sample Tube Std

Air Pressure

PSI	bar	CFM	m³/min
250	17.2	577	16.3
350	24.1	787	22.3
450	31	971	27.5
550	37.9	1156	32.7
650	44.8	1445	40.9
750	51.7	1806	51.1

Air Consumption

Robit[®]
www.robitegroup.com

sales@robitegroup.com

DR55 4.5 METZKE ASSY 1108035

HAMMER ASSEMBLY

DR55 4½" METZKE RETENTION

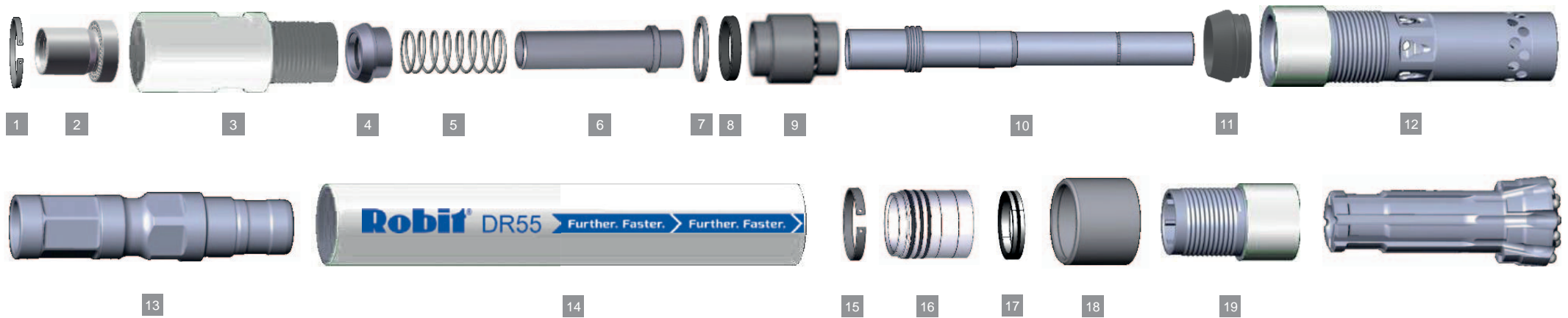

1108037 DR55 4½" METZKE RETENTION HAMMER ASSY

1	1107229	Circlip Internal
2	1059984	Adaptor Screen 4 ½" Metzke
3	1107234	Top Sub 4 ½" Metzke
4	1048189	Check Valve Plunger
5	1009557	Check Valve Spring
6	1048192	Adaptor Tube
7	1009562	Steel Make Up Ring
8	1010627	Make Up Ring
9	1048194	Distributor
10	1048195	Sample Tube Venturi
11	1048196	Sample Tube Mount
12	1048197	Inner Cylinder
13	1107238	Piston
14	1248977	Cylinder
15	1044582	Piston Retaining Ring
16	1009572	Drive Sub Bush
17	1009573	Bit Retaining Ring
18	1051761	Gauge Sleeve 5 7/16" Retention
19	1046868	Drive Sub Retention

Specifications

Bit Shank	DR55
Bit Range	5 3/8" - 137mm to 5 3/4" - 146mm
Top Sub Thread	4 ½" Metzke
Spanner Flat	4.09" - 104mm A/F x 1.96" - 50mm
Overall Length S/S	49.3" - 1252mm
Weight (less bit)	189 lbs - 86kg
Cylinder O.D.	5.1" - 130mm
Oil Consumption	2 - 3 litres per hour

1048201	O Ring Kit
1048200	Make Up Kit
1113851	Sample Tube Std

Air Pressure

Air Pressure		Air Consumption	
PSI	bar	CFM	m ³ /min
250	17.2	577	16.3
350	24.1	787	22.3
450	31	971	27.5
550	37.9	1156	32.7
650	44.8	1445	40.9
750	51.7	1806	51.1

Robit[®]
www.robitegroup.com

sales@robitegroup.com

DR55 4.5 METZKE RETENTION ASSY 1108037

HAMMER ASSEMBLY

DR55 4½" METZKE RETENTION

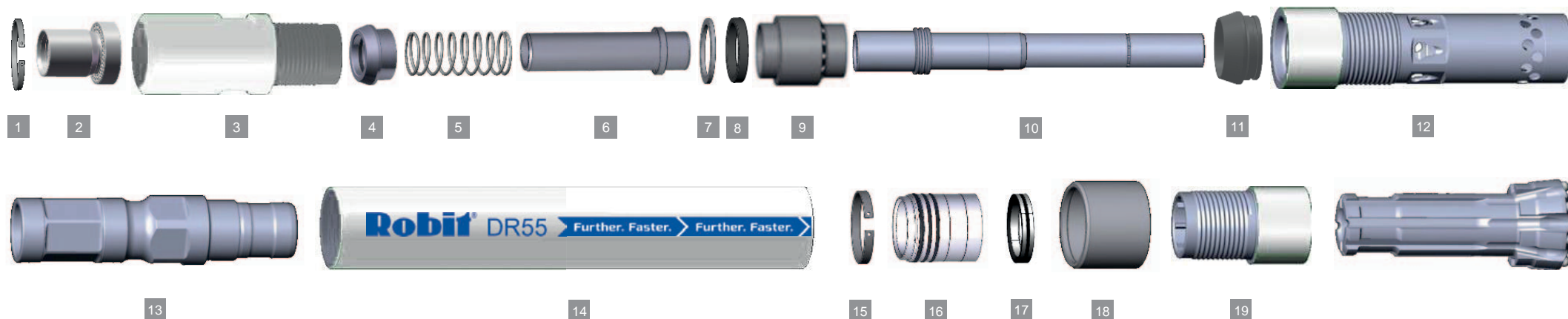

1251582 DR55 4½" METZKE RETENTION HAMMER ASSY

1	1107229	Circlip Internal
2	1059984	Adaptor Screen 4 ½" Metzke
3	1251598	Top Sub 4 ½" Metzke
4	1048189	Check Valve Plunger
5	1009557	Check Valve Spring
6	1048192	Adaptor Tube
7	1009562	Steel Make Up Ring
8	1010627	Make Up Ring
9	1048194	Distributor
10	1048195	Sample Tube Venturi
11	1048196	Sample Tube Mount
12	1048197	Inner Cylinder
13	1107238	Piston
14	1248977	Cylinder
15	1044582	Piston Retaining Ring
16	1009572	Drive Sub Bush
17	1009573	Bit Retaining Ring
18	1051761	Gauge Sleeve 5 7/16" Retention
19	1046868	Drive Sub Retention

Specifications

Bit Shank	DR55
Bit Range	5 3/8" - 137mm to 5 3/4" - 146mm
Top Sub Thread	4 ½" Metzke
Spanner Flat	N/A
Overall Length S/S	49.3" - 1252mm
Weight (less bit)	189 lbs - 86kg
Cylinder O.D.	5.1" - 130mm
Oil Consumption	2 - 3 litres per hour

1048201	O Ring Kit
1048200	Make Up Kit
1113851	Sample Tube Std

Air Pressure

PSI	bar	CFM	m³/min
250	17.2	577	16.3
350	24.1	787	22.3
450	31	971	27.5
550	37.9	1156	32.7
650	44.8	1445	40.9
750	51.7	1806	51.1

Air Consumption

Robit[®]
www.robitegroup.com

sales@robitegroup.com

DR55 4.5 METZKE RETENTION NO FLAT ASSY 1251582

DRILL BIT RANGE

DR38

XHF

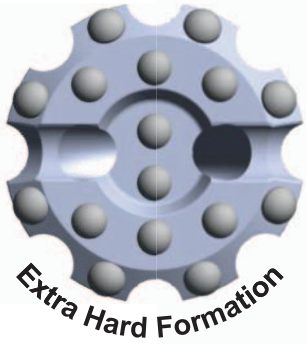

HEAD DIAMETER (mm)	HEAD DIAMETER (inch)	FACE DESIGN	ITEM CODE	RETENTION	NUMBER OF PORTS	WEIGHT (kg)	BUTTON PROFILE	GAUGE ANGLE (°)	GAUGE CARBIDE QTY.	GAUGE CARBIDE DIA. (mm)	GAUGE CARBIDE DIA. (inch)	GAUGE CARBIDE GRADE	FACE CARBIDE QTY.	FACE CARBIDE DIA. (mm)	FACE CARBIDE DIA. (inch)	FACE CARBIDE GRADE	CENTER CARBIDE QTY.	CENTER CARBIDE DIA. (mm)	CENTER CARBIDE DIA. (inch)	CENTER CARBIDE GRADE
102.0	4	XHF	1043635	NO	2	7.3	DM	35	8	12.7	1/2	G30	6	12	-	G20	2	12	-	G20
108.0	4 1/4	XHF	1101408	NO	2	7.5	DM	35	8	14.3	9/16	G30	6	12	-	G20	2	12	-	G20
114.3	4 1/2	XHF	1043638	NO	2	7.7	DM	35	8	14.3	9/16	G30	6	12.7	1/2	G20	3	12.7	1/2	G20

DRILL BIT RANGE

DR43

XHF



DC



HEAD DIAMETER (mm)	HEAD DIAMETER (inch)	FACE DESIGN	ITEM CODE	RETENTION	NUMBER OF PORTS	WEIGHT (kg)	BUTTON PROFILE	GAUGE ANGLE (°)	GAUGE CARBIDE QTY.	GAUGE CARBIDE DIA. (mm)	GAUGE CARBIDE DIA. (inch)	GAUGE CARBIDE GRADE	FACE CARBIDE QTY.	FACE CARBIDE DIA. (mm)	FACE CARBIDE DIA. (inch)	FACE CARBIDE GRADE	CENTER CARBIDE QTY.	CENTER CARBIDE DIA. (mm)	CENTER CARBIDE DIA. (inch)	CENTER CARBIDE GRADE
117.5	4 5/8	XHF	1270096	NO	2	10.7	DM	35	8	14.3	9/16	G30	6	12.7	1/2	G20	4	12.7	1/2	G20
120.7	4 3/4	XHF	1270097	NO	2	10.8	DM	35	8	14.3	9/16	G30	6	12.7	1/2	G20	4	12.7	1/2	G20
123.8	4 7/8	XHF	1270098	NO	2	11	DM	35	8	14.3	9/16	G30	6	14.3	9/16	G20	4	12.7	1/2	G20
127.0	5	XHF	1270099	NO	2	11.5	DM	35	8	15.9	5/8	G30	6	14.3	9/16	G20	4	12.7	1/2	G20
158.8	6 1/4	DC	1270095	NO	2	13.6	DM	35	8	15.9	5/8	G30	8	15.9	5/8	G20	4	12.7	1/2	G20

DRILL BIT RANGE

DR44

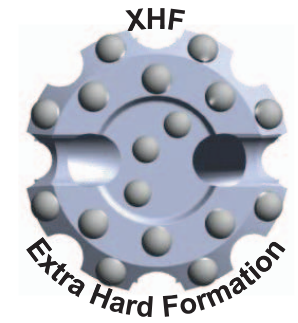
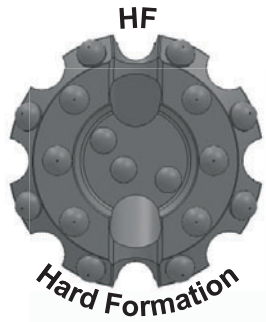

HEAD DIAMETER (mm)	HEAD DIAMETER (inch)	FACE DESIGN	ITEM CODE	RETENTION	NUMBER OF PORTS	WEIGHT (kg)	BUTTON PROFILE	GAUGE ANGLE (°)	GAUGE CARBIDE QTY.	GAUGE CARBIDE DIA. (mm)	GAUGE CARBIDE DIA. (inch)	GAUGE CARBIDE GRADE	FACE CARBIDE QTY.	FACE CARBIDE DIA. (mm)	FACE CARBIDE DIA. (inch)	FACE CARBIDE GRADE	CENTER CARBIDE QTY.	CENTER CARBIDE DIA. (mm)	CENTER CARBIDE DIA. (inch)	CENTER CARBIDE GRADE
130.2	5 1/8	XHF	1194335	NO	2	14.7	DM	35	8	15.9	5/8	G30	6	15.9	5/8	G30	3	14.3	9/16	G20
133.4	5 1/4	XHF	1259378	NO	2	14.4	DM	35	8	15.9	5/8	G30	6	15.9	5/8	G30	4	14.3	9/16	G20
133.4	5 1/4	XHF	1046952	NO	2	14.4	DM	35	8	15.9	5/8	G30	6	15.9	5/8	G30	4	14.3	9/16	G20
136.5	5 3/8	XHF	1101419	NO	2	15.3	DM	35	8	15.9	5/8	G30	6	15.9	5/8	G30	3	14.3	9/16	G20
139.7	5 1/2	DC	1046955	NO	2	15.5	DM	35	8	15.9	5/8	G30	4	15.9	5/8	G30	3	14.3	9/16	G20
139.7	5 1/2	HF	1101420	NO	2	15.7	DM	35	8	15.9	5/8	G30	6	15.9	5/8	G30	3	14.3	9/16	G20
139.7	5 1/2	XHF	1048174	NO	2	15.7	DM	35	8	15.9	5/8	G30	6	15.9	5/8	G30	3	14.3	9/16	G20
165.1	6 1/2	DC	1101421	NO	2	17.7	DM	35	8	18	-	G20	8	15.9	5/8	G20	2	15.9	5/8	G20
190.5	7 1/2	DC	1059558	NO	2	22	DM	35	8	18	-	G20	10	15.9	5/8	G20	2	15.9	5/8	G20

Robit[®]
www.robbitgroup.com

sales@robbitgroup.com

RC DRILL BIT RANGE

DRILL BIT RANGE

DR53



HEAD DIAMETER (mm)	HEAD DIAMETER (inch)	FACE DESIGN	ITEM CODE	RETENTION	NUMBER OF PORTS	WEIGHT (kg)	BUTTON PROFILE	GAUGE ANGLE (°)	GAUGE CARBIDE QTY.	GAUGE CARBIDE DIA. (mm)	GAUGE CARBIDE DIA. (inch)	GAUGE CARBIDE GRADE	FACE CARBIDE QTY.	FACE CARBIDE DIA. (mm)	FACE CARBIDE DIA. (inch)	FACE CARBIDE GRADE	CENTER CARBIDE QTY.	CENTER CARBIDE DIA. (mm)	CENTER CARBIDE DIA. (inch)	CENTER CARBIDE GRADE
136.5	5 3/8	DC	1101424	NO	2	16.4	DM	35	8	15.9	5/8	G30	4	15.9	5/8	G30	3	14.3	9/16	G20
136.5	5 3/8	XHF	1101423	NO	2	16.6	DM	35	8	15.9	5/8	G30	6	15.9	5/8	G30	3	14.3	9/16	G20
136.5	5 3/8	XHF	1216712	YES	2	18	DM	35	8	15.9	5/8	G30	6	15.9	5/8	G30	3	14.3	9/16	G20
139.7	5 1/2	DC	1101425	NO	2	16.7	DM	35	8	15.9	5/8	G30	4	15.9	5/8	G30	3	14.3	9/16	G20
139.7	5 1/2	XHF	1101437	NO	2	16.5	DM	35	8	15.9	5/8	G30	6	15.9	5/8	G30	3	14.3	9/16	G20
139.7	5 1/2	XHF	1216713	YES	2	18.1	DM	35	8	15.9	5/8	G30	6	15.9	5/8	G30	3	14.3	9/16	G20
142.9	5 5/8	DC	1201146	NO	2	16.9	DM	35	8	15.9	5/8	G30	6	15.9	5/8	G30	3	14.3	9/16	G20
142.9	5 5/8	XHF	1216714	YES	2	18.3	DM	35	8	15.9	5/8	G30	6	15.9	5/8	G30	3	14.3	9/16	G20
158.8	6 1/4	DC	1102120	NO	2	18.3	DM	35	8	15.9	5/8	G20	6	15.9	5/8	G20	3	14.3	9/16	G20
165.1	6 1/2	DC	1101441	NO	2	19	DM	35	8	18	-	G20	8	15.9	5/8	G20	2	15.9	5/8	G20
190.5	7 1/2	DC	1101443	NO	2	25.2	DM	35	8	18	-	G20	10	15.9	5/8	G20	2	15.9	5/8	G20

Robit[®]
www.robbitgroup.com

sales@robbitgroup.com
RC DRILL BIT RANGE

DRILL BIT RANGE

DR55

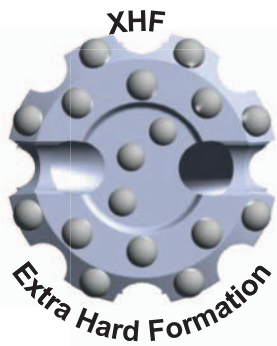

HEAD DIAMETER (mm)	HEAD DIAMETER (inch)	FACE DESIGN	ITEM CODE	RETENTION	NUMBER OF PORTS	WEIGHT (kg)	BUTTON PROFILE	GAUGE ANGLE (°)	GAUGE CARBIDE QTY.	GAUGE CARBIDE DIA. (mm)	GAUGE CARBIDE DIA. (inch)	GAUGE CARBIDE GRADE	FACE CARBIDE QTY.	FACE CARBIDE DIA. (mm)	FACE CARBIDE DIA. (inch)	FACE CARBIDE GRADE	CENTER CARBIDE QTY.	CENTER CARBIDE DIA. (mm)	CENTER CARBIDE DIA. (inch)	CENTER CARBIDE GRADE
136.5	5 3/8	XHF	1193930	NO	2	17.9	DM	35	8	15.9	5/8	G30	6	15.9	5/8	G30	3	14.3	9/16	G20
136.5	5 3/8	XHF	1101444	YES	2	17.5	DM	35	8	15.9	5/8	G30	6	15.9	5/8	G30	3	14.3	9/16	G20
139.7	5 1/2	XHF	1194008	NO	2	18	DM	35	8	15.9	5/8	G30	6	15.9	5/8	G30	3	14.3	9/16	G20
139.7	5 1/2	XHF	1045322	YES	2	18.6	DM	35	8	15.9	5/8	G30	6	15.9	5/8	G30	3	14.3	9/16	G20
142.9	5 5/8	XHF	1194011	NO	2	18.2	DM	35	8	15.9	5/8	G30	6	15.9	5/8	G30	3	14.3	9/16	G20
142.9	5 5/8	XHF	1054746	YES	2	18.8	DM	35	8	15.9	5/8	G30	6	15.9	5/8	G30	3	14.3	9/16	G20
146.0	5 3/4	XHF	1194700	NO	2	18.4	DM	35	8	15.9	5/8	G30	6	15.9	5/8	G30	3	14.3	9/16	G20
146.0	5 3/4	XHF	1101492	YES	2	18.9	DM	35	8	15.9	5/8	G30	6	15.9	5/8	G30	3	14.3	9/16	G20
158.8	6 1/4	DC	1048207	YES	2	19.6	DM	35	8	15.9	5/8	G20	6	15.9	5/8	G20	3	14.3	9/16	G20
190.5	7 1/2	DC	1045566	NO	2	24.3	DM	35	8	18	-	G20	10	15.9	5/8	G20	2	15.9	5/8	G20
190.5	7 1/2	DC	1046865	YES	2	23.5	DM	35	8	18	-	G20	10	15.9	5/8	G20	2	14.3	9/16	G20

Robit[®]
www.robbitgroup.com

sales@robbitgroup.com

RC DRILL BIT RANGE



FURTHER. FASTER.



Robit reserves all rights to any changes in the products and the specifications without prior notice.
Printed: September 2018
Copyright © 2018 by Robit Plc

Robit[®]

24-26 Gauge Circuit
Canning Vale WA 6155
Australia

Tel: +61 8 6245 5600
Fax: +61 8 6245 5699
sales@robitgroup.com
robitgroup.com