

# ROBIT® PILING PRODUCTS

Pilot & Ring Bits

OD Bits

Rotary Bits

DTH Bits

DTH Hammers

Shock Absorbers

Drill Pipes

Subs, Check Valves & Hammer Sleeves

Accessories



FURTHER. FASTER.

**Robit**®



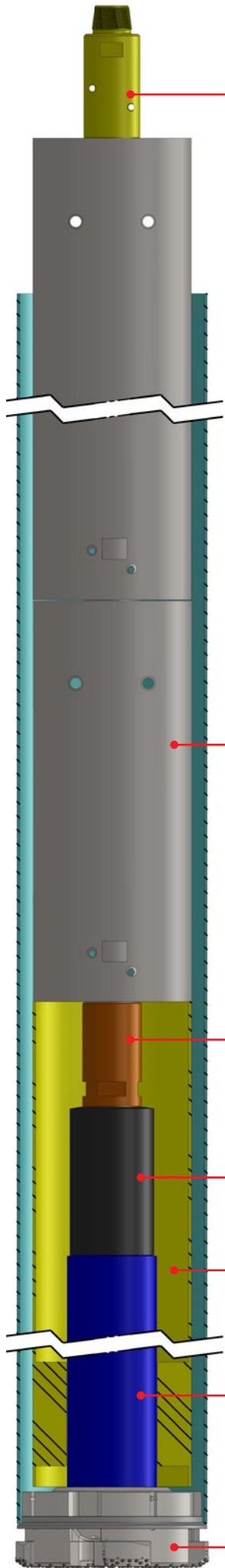

Accessories.....	19
Subs & Check Valves.....	18
Drill Pipes.....	15
Subs & Check Valves.....	18
Shock Absorbers.....	15
Hammer Sleeve.....	18
DTH Hammers.....	14
DTH Bits .....	13
Rotary Bits .....	11
Pilots & Ring Bits .....	4

# Pilot & Ring Bits

System size    Standard shank design

[mm]	[in]	
114,3	4 ½	DHD 3,5"
127,0	5	DHD 3,5", DHD 340, TD 40
139,7	5 ½	DHD 340, QL 40, SD-4, COP 42/44, TD 40
152,4	6	DHD 340, QL 40, SD-4, COP 42/44, TD 40
168,3	6 ⅝	DHD 350, QL 50, SD-5, COP 52/54
177,8	7	DHD 350, QL 50, SD-5, COP 52/54
193,7	7 ⅝	DHD 360, QL 60, SD-6
219,1	8 ⅝	DHD 360, QL 60, SD-6
244,5	9 ⅝	DHD 360/380, QL 60/80, SD-6/8
254,0	10	DHD 380, QL 80, SD-8
267,0	10 ½	DHD 380, QL 80, SD-8
273,0	10 ¾	DHD 380, QL 80, SD-8
323,9	12 ¾	DHD 380, QL 80, SD-8/10, N125
355,6	14	DHD 112, QL 120, SD-10/12, N120/125
406,4	16	DHD 112, QL 120, SD-10/12, N120/125
457,2	18	DHD 112/S, QL 120, SD-12/15, N120/125
508,0	20	DHD 112S, QL 120/200, SD-15/18, N125/180
558,8	22	DHD 112S, QL 120/200, SD-15/18, N180
609,6	24	QL 200, SD-18, N180
660,4	26	QL 200, SD-18, N180/240
711,2	28	QL 200S, SD-18, N180/240
762,0	30	QL 200S, SD-18, N180/240
812,8	32	QL 200S, N180/240
914,4	36	QL 200S, N180/240/330
1016,0	40	QL 300, N240/330
1220,0	48	QL300S, N240/330, SS30
1320,0	52	H331

All inquiries for other shank designs please contact Robit sales.



**DTH-RoX++ . Ring bit ID optimized**

Order code	Casing				Ring bit				Pilot bit		Hammer	Weight	
	[mm]	[in]	[mm]	[in]	[mm]	[in]	[mm]	[in]	[mm]	[in]		[kg]	[kg]
DTH-RoX+ 114,3/5	114,3	4 ½	5	0.197	91	3.583	128	5.039	102	4.016	3 ½"	3.4	6.6
DTH-RoX++ 139,7/5,6	139,7	5 ½	5,6	0.220	116	4.567	154	6.063	127,5	5.020	4"	5.2	13.9
DTH-RoX++ 168,3/6	168,3	6 ⅝	6	0.236	142	5.591	184	7.244	155	6.102	5"	7.1	23.8
DTH-RoX+ 177,8/6,9	177,8	7	6,9	0.272	153,5	6.043	195	7.677	162	6.378	6"	7.0	27.0
DTH-RoX++ 193,7/6	193,7	7 ⅝	6	0.236	167	6.575	212	8.346	180	7.087	6"	9.0	35.2
DTH-ROX+ 219,1/5	219,1	8 ⅝	5	0.197	192	7.559	238	9.370	207	8.150	6"	10.4	37.8
DTH-RoX+ 219,1/6	219,1	8 ⅝	6	0.236	186	7.323	234	9.213	205	8.071	6"	10.0	37.2
DTH-RoX+ 273/8	273	10 ¾	8	0.315	232	9.134	292	11.496	255	10.039	8"	19.8	78.8
DTH-RoX++ 273/8	273	10 ¾	8	0.315	238	9.370	297,5	11.713	255	10.039	8"	19.4	74.3
DTH-RoX+ 323,9/8	323,9	12 ¾	8	0.315	281	11.063	343	13.504	306	12.047	8"	26.4	106.9

**Heavy duty rings**

DTH-RoX++ HD 101,6/5	101,6	4	5	0.197	82,5	3.248	118	4.646	90,4	3.559	3"	3.2	6.0
DTH-RoX++ HD 139,7/5,6	139,7	5 ½	5,6	0.220	116	4.567	156	6.142			4"	6.3	13.9
DTH-RoX++ HD 168,3/6	168,3	6 ⅝	6	0.236	142	5.591	186	7.323			5"	8.6	23.8
DTH-RoX++ HD 193,7/6	193,7	7 ⅝	6	0.236	167	6.575	214	8.425			6"	10.9	35.2
DTH-RoX+ HD 219,1/6	219,1	8 ⅝	6	0.236	186	7.323	241	9.488			6"	11.4	37.2

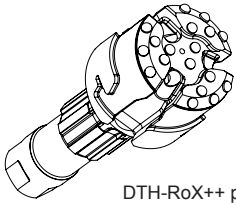

DTH-RoX++ pilot bit

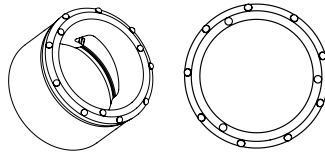
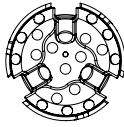

DTH-RoX++ ring bit

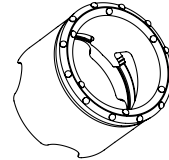

Heavy Duty rings

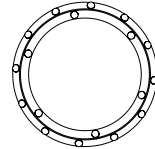

**DTH-RoX+ (FC – Flow Control also available) . For thick wall casings**

Order code	Casing				Ring bit				Pilot bit		Hammer	Weight	
	[mm]	[in]	[mm]	[in]	[mm]	[in]	[mm]	[in]	[mm]	[in]		[kg]	[kg]
DTH-RoX+ 114,3/10	114,3	4 ½	10	0.394	78	3.071	124	4.882	92,5	3.642	3"	3.7	5.5
DTH-RoX+ 139,7/10	139,7	5 ½	10	0.394	94	3.701	150	5.906	117,5	4.626	4"	6.2	9.7
DTH-RoX+ 168,3/12,7	168,3	6 ⅝	12,7	0.500	121	4.764	178	7.008	140	5.512	5"	8.4	17.8
DTH-RoX+ 193,7/12,7	193,7	7 ⅝	12,7	0.500	148	5.827	203	7.992	167	6.575	6"	10.6	29.2
DTH-RoX+ 219,1/12,7	219,1	8 ⅝	12,7	0.500	167	6.575	234	9.213	191	7.520	6"	13.9	34.4
DTH-RoX+ 244,5/12,7	244,5	9 ⅝	12,7	0.500	194	7.638	260	10.236	216	8.504	6"	18.0	42.1
DTH-RoX+ 273/12,7	273	10 ¾	12,7	0.500	219	8.622	292	11.496	246	9.685	8"	22.3	68.7
DTH-RoX+ 323,9/12,7	323,9	12 ¾	12,7	0.500	270	10.630	342	13.465	295	11.614	8-10"	32.8	102.6
DTH-RoX+ 355,6/12,7	355,6	14	12,7	0.500	282	11.102	367	14.449	323	12.717	8 - 12"	27.0	154.0
DTH-RoX+ 406,4/12,7	406,4	16	12,7	0.500	328	12.913	419	16.496	374	14.724	10-12"	47.4	236.0
DTH-RoX+ 457/15	457	18	15	0.591	374	14.724	470	18.504	420	16.535	12-15"	44.8	281.8
DTH-RoX+ 508,0/15	508	20	15	0.591	414	16.299	521	20.512	472	18.583	12-15"	71.0	540.0
DTH-RoX+ 609,6/16	609,6	24	16	0.630	513	20.197	622	24.488	570	22.441	18"	90.0	670.0
DTH-RoX+ 711/16	711	28	16	0.630	610	24.016	725	28.543	670	26.378	24"	96.5	759.1
DTH-RoX+ 762/20	762	36	20	0.787	654	25.748	774	30.472	712	28.031	24"	105.0	838.5
DTH-RoX+ 813/16	813	32	16	0.630	715	28.150	825	32.480	775	30.512	20-24"	123.1	1193.6
DTH-RoX+ 914/20	914	36	20	0.787	805	31.693	928	36.535	863	33.976	20-24"	147.4	1426.3
DTH-RoX+ 1016/20	1016	40	20	0.787	907	35.709	1035	40.748	961	37.835	24"	175.0	1652.0

**Heavy duty rings**

DTH-RoX+ HD 406,4/12,7	406,4	16	12,7	0.500	328	12.913	416	16.378			10-12"	46.4	236.0
DTH-RoX+ HD 508,0/15	508	20	15	0.591	414	16.299	520	20.472			12-15"	69.8	540.0
DTH-RoX+ HD 609,6/16	609,6	24	16	0.630	513	20.197	620	24.409			18"	87.2	670.0
DTH-RoX+ HD 711/16	711	28	16	0.630	610	24.016	725	28.543			24"	96.5	759.1
DTH-RoX+ HD 762/20	762	36	20	0.787	654	25.748	774	30.472			24"	105.0	838.5
DTH-RoX+ HD 813/16	813	32	16	0.630	715	28.150	825	32.480			20-24"	119.8	1193.6
DTH-RoX+ HD 1016/20	1016	40	20	0.787	907	35.709	1035	40.748			24"	179.0	1652.0

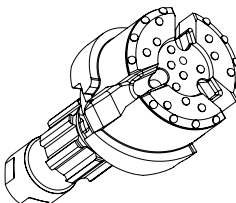

DTH-RoX+ pilot bit

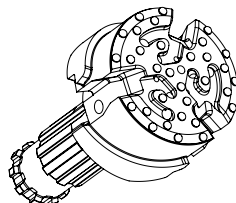
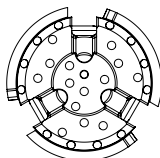

DTH-RoX+ FC pilot bit

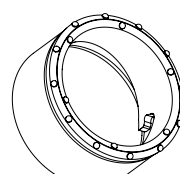
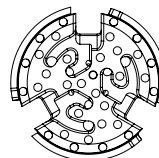

114,3 - 355,6

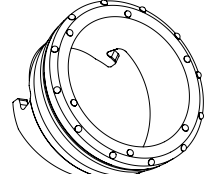

406,4 - 914

DTH-RoX+ (FC) ring bit

# Pilot & Ring Bits

## DTH Prime

Order code	Casing				Ring bit				Pilot bit		Hammer	Weight	
	[mm]	[in]	[mm]	[in]	[mm]	[in]	[mm]	[in]	[mm]	[in]		[kg]	[kg]
DTH Prime 114,3/10	114,3	4 ½	10	0.394	80	3.150	135	5.315	91,5	3.602	3"	4.4	6.1
DTH Prime 139,7/10	139,7	5 ½	10	0.394	100	3.937	161	6.339	116	4.567	4"	5.8	10.2
DTH Prime 168,3/12,7	168,3	6 ⅝	12,7	0.500	126	4.961	191	7.520	140	5.512	5"	8.4	17.9
DTH Prime 219,1/12,7	219,1	8 ⅝	12,7	0.500	172	6.772	241	9.488	190	7.480	6"	11.6	30.6
DTH Prime 273/12,7	273	10 ¾	12,7	0.500	222	8.740	304	11.969	245	9.646	8"	17.5	66.3
DTH Prime XL2 273/12,7	273	10 ¾	12,7	0.500	222	8.740	327	12.874	245	9.646	8"	21.0	66.3
DTH Prime 323,9/12,7	323,9	12 ¾	12,7	0.500	272	10.709	350	13.780	295	11.614	8-10"	20.2	77.2
DTH Prime XL2 323,9/12,7	323,9	12 ¾	12,7	0.500	272	10.709	377	14.843	295	11.614	8-10"	24.1	77.2
DTH Prime 406,4/12,7	406,4	16	12,7	0.500	354	13.937	442	17.402	374	14.724	10-12"	34.0	180.0
DTH Prime XL2 406,4/12,7	406,4	16	12,7	0.500	354	13.937	460	18.110	374	14.724	10-12"	36.9	180.0
DTH Prime 609,6/16	609,6	24	16	0.630	540	21.260	650	25.591	568	22.362	18"	72.5	572.2
DTH Prime 813/23	813	32	23	0.906	723	28.465	860	33.858	757	29.803	20-24"	119.0	1220.0
DTH Prime 914/23	914	36	23	0.906	824	32.441	962	37.874	857	33.740	20-24"	131.4	1430.0
DTH Prime 1016/23	1016	40	23	0.906	932	36.693	1062	41.811	960	37.795	24"	172.5	2400.0
DTH Prime 1220/25,4	1220	48	25,4	1.000	1129	44.449	1272	50.079	1157	45.551	33"	221.0	3190.0

## DTH Prime DT (Drill Through)

Order code	Casing				Ring bit				Pilot bit		Hammer	Weight	
	[mm]	[in]	[mm]	[in]	[mm]	[in]	[mm]	[in]	[mm]	[in]		[kg]	[kg]
DTH Prime DT 114,3/10	114,3	4 ½	10	0.394	80	3.150	135	5.315	90,6	3.567	3"	4.4	6.1
DTH Prime DT 139,7/10	139,7	5 ½	10	0.394	100	3.937	161	6.339	114	4.488	4"	5.8	10.4
DTH Prime DT 152,4/12,7	152,4	6	12,7	0.500	106	4.173	175	6.890	124	4.882	4"	7.5	11.4
DTH Prime DT 168,3/12,7	168,3	6 ⅝	12,7	0.500	126	4.961	191	7.520	138	5.433	5"	8.4	18.1
DTH Prime DT 193,7/12,7	193,7	7 ⅝	12,7	0.500	148	5.827	216	8.504	164	6.457	6"	10.0	28.7
DTH Prime DT 219,1/12,7	219,1	8 ⅝	12,7	0.500	172	6.772	241	9.488	188	7.402	6"	11.6	30.0
DTH Prime DT 244,5/12,7	244,5	9 ⅝	12,7	0.500	194	7.638	268	10.551	214	8.425	6"	14.1	54.2
DTH Prime DT 273/12,7	273	10 ¾	12,7	0.500	222	8.740	304	11.969	243	9.567	8"	17.5	65.1
DTH Prime DT 323,9/12,7	323,9	12 ¾	12,7	0.500	272	10.709	350	13.780	294	11.575	8-10"	20.2	77.8
DTH Prime DT 339,7/12,7	339,7	13 ⅜	12,7	0.500	286	11.260	364	14.331	308	12.126	8-10"	24.0	85.0
DTH Prime DT 406,4/12,7	406,4	16	12,7	0.500	354	13.937	442	17.402	374	14.724	10-12"	34.0	180.0
DTH Prime DT 609,6/16	609,6	24	16	0.630	540	21.260	650	25.591	568	22.362	18"	72.5	572.2
DTH Prime DT 813/23	813	32	23	0.906	723	28.465	860	33.858	757	29.803	20-24"	119.0	1220.0
DTH Prime DT 914/23	914	36	23	0.906	824	32.441	962	37.874	857	33.740	20-24"	131.4	1430.0
DTH Prime DT 1016/23	1016	40	23	0.906	932	36.693	1062	41.811	960	37.795	24"	172.5	2400.0
DTH Prime DT 1220/25,4	1220	48	25,4	1.000	1129	44.449	1272	50.079	1157	45.551	33"	221.0	3190.0

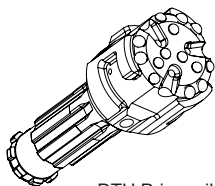

DTH Prime pilot bit

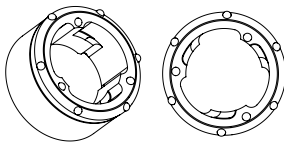

DTH Prime ring bit

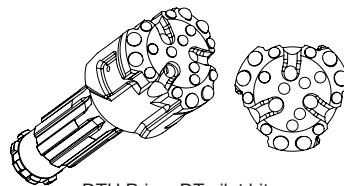

DTH Prime DT pilot bit

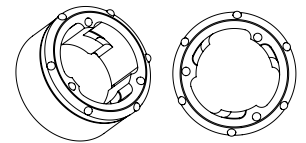

DTH Prime DT ring bit

## DTH SF

Order code	Pipe				Pilot bit				Wings	Hammer	Weight	
	[mm]	[in]	[mm]	[in]	[mm]	[in]	[mm]	[in]			[pcs]	[kg]
DTH SF 273/12,7	273,0	10 ¾	12,7	0.500	287	11.299	245	9.646	3	8"	86.1	4.2
DTH SF 323,9/12,7	323,9	12 ¾	12,7	0.500	338	13.307	294,5	11.594	3	8"	117.5	5.1
DTH SF XL2 323,9/12,7	323,9	12 ¾	12,7	0.500	374	14.724	294,5	11.594	3	8"	127.9	5.1
DTH SF 406,4/12,7	406,4	16	12,7	0.500	420	16.535	376	14.803	3	10-12"	215.9	6.4
DTH SF XL2 406,4/12,7	406,4	16	12,7	0.500	460	18.110	376	14.803	3	10-12"	227.9	6.4
DTH SF 508/16	508	20	16	0.630	522	20.551	472	18.583	3	12"	353.0	8.6
DTH SF XL2 508/16	508	20	16	0.630	562	22.126	472	18.583	3	12"	365.0	8.6
DTH SF 609,6/16	609,6	24	16	0.630	624	24.567	571	22.480	3	18"	806.4	11.4
DTH SF XL2 609,6/16	609,6	24	16	0.630	664	26.142	571	22.480	3	18"	820.1	11.4
DTH SF 711/16	711	28	16	0.630	725	28.543	671	26.417	3	18"	1090.0	15.8
DTH SF XL2 711/16	711	28	16	0.630	765	30.118	671	26.417	3	18"	1095.0	15.8
DTH SF 813/16	813	32	16	0.630	826	32.520	772	30.394	3	18"	1455.8	19.6
DTH SF XL2 813/16	813	32	16	0.630	867	34.134	772	30.394	3	18"	1471.5	19.6
DTH SF 914/20	914	36	20	0.787	927	36.496	864	34.016	4	24-30"	1750.0	25.4
DTH SF XL2 914/20	914	36	20	0.787	968	38.110	864	34.016	4	24-30"	1770.0	25.4
DTH SF 1016/16	1016	40	16	0.630	1030	40.551	973	38.307	5	24-33"	2049.4	26.0
DTH SF XL2 1016/16	1016	40	16	0.630	1070	42.126	973	38.307	5	24-33"	2080.0	26.0
DTH SF 1220/20	1220	48	20	0.787	1234	48.583	1135	44.685	6	30-33"	2970.0	35.0
DTH SF XL2 1220/20	1220	48	20	0.787	1274	50.157	1135	44.685	6	30-33"	3000.0	35.0

When ordering, information about casing diameters (OD and ID) is necessary.

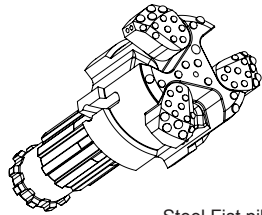

Steel Fist pilot bit

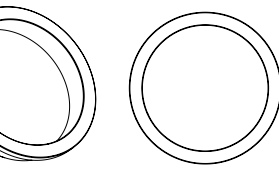
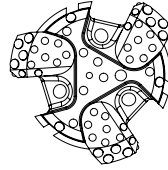

Steel Fist impact shoe

## DTH-RoX MU

Order code	Casing				Ring bit				Pilot bit	Hammer	Weight		
	[mm]	[in]	[mm]	[in]	[mm]	[in]	[mm]	[in]			[kg]	[kg]	
DTH-RoX MU 114,3/10	114,3	4 ½	10	0.394	78	3.071	122	4.803	92,5	3.642	3"	5.4	6.4
DTH-RoX MU 127/10	127,0	5	10	0.394	95	3.740	136	5.354	105,2	4.142	3 ½"	6.4	9.0
DTH-RoX MU 139,7/10	139,7	5 ½	10	0.394	104	4.094	147	5.787	117,5	4.626	4"	7.5	13.2
DTH-RoX MU 152,4/10	152,4	6	10	0.394	115,8	4.559	159,5	6.280	130,6	5.142	4"	8.9	16.9
DTH-RoX MU 168,3/10	168,3	6 ⅝	10	0.394	129	5.079	178	7.008	146	5.748	5"	10.7	21.6
DTH-RoX MU 177,8/10	177,8	7	10	0.394	142	5.591	191	7.520	155	6.102	5"	11.9	27.5
DTH-RoX MU 193,7/10	193,7	7 ⅝	10	0.394	154	6.063	204	8.031	172	6.772	6"	13.5	35.0
DTH-RoX MU 219,1/12,7	219,1	8 ⅝	12,7	0.500	172	6.772	229	9.016	192	7.717	6"	16.8	40.0
DTH-RoX MU 273,0/12,7	273	10 ¾	12,7	0.500	211	8.307	286	11.260	243	9.567	8"	32.0	80.0
DTH-RoX MU 323,9/12,7	323,9	12 ¾	12,7	0.500	257	10.118	338	13.307	293	11.535	8"	51.0	120.0
DTH-RoX MU 355,6/12,7	355,6	14	12,7	0.500	305	12.008	368	14.488	326	12.835	8-12"	46.9	173.8
DTH-RoX MU 406,4/12,7	406,4	16	12,7	0.500	328	12.913	423	16.654	374	14.724	10-12"	75.1	236.0
DTH-RoX MU 508,0/15	508	20	15	0.591	414	16.299	526	20.709	472	18.583	12-15"	120.0	540.0
DTH-RoX MU 609,6/12,7	609,6	24	12,7	0.500	554	21.811	645	25.394	581	22.874	18"	150.0	780.0

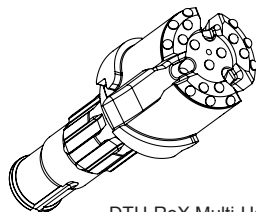

DTH-RoX Multi-Use pilot bit

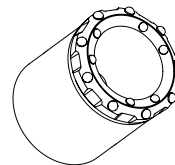
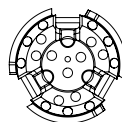

DTH-RoX Multi-Use ring bit

# Pilot & Ring Bits

## DTH SR

Order code	Casing				Ring bit				Pilot bit		Hammer	Weight	
	[mm]	[in]	[mm]	[in]	[mm]	[in]	[mm]	[in]	[mm]	[in]		[kg]	[kg]
DTH SR 168,3/12,7	168,3	6 5/8	12,7	0.500	102	4.016	182	7.165	140,5	5.531	5"	6.8	20.0
DTH SR 219,1/12,7	219,1	8 5/8	12,7	0.500	127	5.000	233	9.173	190,7	7.508	6"	10.0	36.4
DTH SR XL2 219,1/12,7	219,1	8 5/8	12,7	0.500	127	5.000	273	10.748	190,7	7.508	6"	14.8	36.4
DTH SR 273,0/12,7	273,0	10 3/4	12,7	0.500	194	7.638	287	11.299	244,6	9.630	8"	12.9	74.3
DTH SR XL2 273,0/12,7	273,0	10 3/4	12,7	0.500	194	7.638	327	12.874	244,6	9.630	8"	18.5	74.3
DTH SR 323,9/12,7	323,9	12 3/4	12,7	0.500	240	9.449	338	13.307	294,5	11.594	8-10"	15.9	97.4
DTH SR XL2 323,9/12,7	323,9	12 3/4	12,7	0.500	240	9.449	378	14.882	294,5	11.594	8-10"	22.5	97.4
DTH SR 406,4/12,7	406,4	16	12,7	0.500	322	12.677	420	16.535	376	14.803	10-12"	20.4	196.2
DTH SR XL2 406,4/12,7	406,4	16	12,7	0.500	322	12.677	460	18.110	376	14.803	10-12"	30.5	196.2
DTH SR 508/16	508	20	16	0.630	417	16.417	522	20.551	472	18.583	12"	26.6	297.0
DTH SR XL2 508/16	508	20	16	0.630	417	16.417	562	22.126	472	18.583	12"	36.6	297.0
DTH SR 609,6/16	609,6	24	16	0.630	504	19.843	625	24.606	571	22.480	18"	40.0	670.0
DTH SR XL2 609,6/16	609,6	24	16	0.630	504	19.843	664	26.142	571	22.480	18"	52.5	670.0
DTH SR 711/16	711	28	16	0.630	616	24.252	726	28.583	671	26.417	24"	44.0	730.0
DTH SR XL2 711/16	711	28	16	0.630	616	24.252	765	30.118	671	26.417	24"	58.0	730.0
DTH SR XL 813/16	813	32	16	0.630	706	27.795	845	33.268	772	30.394	20-24"	60.0	1010.0
DTH SR 863/23	863	34	23	0.906	742	29.213	875	34.449	808	31.811	20-24"	57.0	1020.0

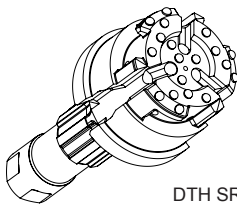

DTH SR pilot bit

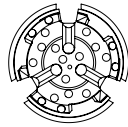

DTH SR ring bit

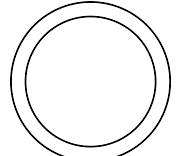
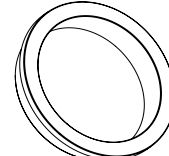
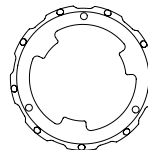
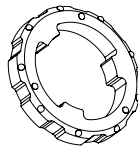

DTH SR impact shoe

## DTH-RoX NS

Order code	Casing				Ring bit				Pilot bit		Hammer	Weight	
	[mm]	[in]	[mm]	[in]	[mm]	[in]	[mm]	[in]	[mm]	[in]		[kg]	[kg]
DTH-RoX NS 114,3/10	114,3	4 1/2	10	0.394	82	3.228	124	4.882	92,5	3.642	3"	1.6	7.7
DTH-RoX NS 139,7/10	139,7	5 1/2	10	0.394	104	4.094	150	5.906	116	4.567	4"	2.2	14.0
DTH-RoX NS 152,4/12,7	152,4	6	12,7	0.500	114	4.488	160	6.299	126	4.961	4"	2.9	16.7
DTH-RoX NS 168,3/10	168,3	6 5/8	10	0.394	129	5.079	178	7.008	146	5.748	5"	3.6	24.4
DTH-RoX NS 177,8/10	177,8	7	10	0.394	142	5.591	191	7.520	152	5.984	5"	3.3	28.0
DTH-RoX NS 219,1/10	219,1	8 5/8	10	0.394	185	7.283	233	9.173	197	7.756	6"	4.0	48.6

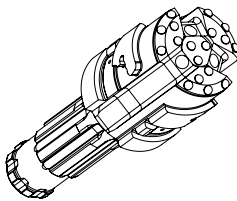

DTH-RoX NS pilot bit

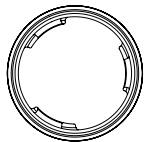
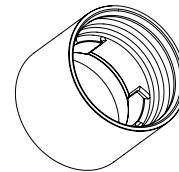
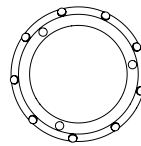
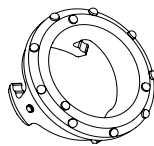
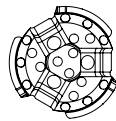

DTH-RoX NS ring bit

DTH-RoX NS casing extension



# Pilot & Ring Bits

## CDS-R

Order code	Pipe				Pilot bit				Wings [pcs]	Hammer [kg]	Weight [kg]	
	[mm]	[in]	[mm]	[in]	[mm]	[in]	[mm]	[in]				
CDS 240R	273,0	10 ¾	13	0.512	296	13.307	240	9.450	3	8"	136.0	4.9
CDS 280R	324,0	12 ¾	19	0.748	345	13.583	281	11.063	3	10"	200.0	16.5
CDS 295R	324,0	12 ¾	8	0.315	344	13.543	295	11.615	3	10"	250.0	11.0
CDS 310R	355,6	14	22,2	0.874	385	15.157	310	12.204	3	10"	300.0	19.0
CDS 315R	355,6	14	22,2	0.874	385	15.157	315	12.402	3	10"	350.0	19.0
CDS 360R	406,4	16	25,4	1.000	438	17.244	360	14.173	3	12"	380.0	27.0
CDS 365R	406,4	16	19,4	0.764	438	17.244	365	14.370	3	14"	401.0	27.0
CDS 460R	508	20	25	0.984	540	21.260	460	18.110	3	14"	1350.0	40.0
CDS 510R	559	22	26	1.024	583	22.953	510,5	20.100	3	14-18"	1230.0	28.0
CDS 560R	610	24	20	0.787	640	25.197	560	22.047	3	18"	1350.0	30.0
CDS 610R	660	26	27	1.063	692	27.244	610	24.016	3	18-24"	1790.0	36.0
CDS 660R	762	30	25,4	1.000	792	31.180	661,5	26.040	3	18-24"	1970.0	49.0
CDS 745R	813	32	33	1.299	843	33.189	746	29.370	4	24"	2500.0	55.0
CDS 835R	914,4	36	42,4	1.669	950	37.400	835	32.874	4	24"	2860.0	70.0

When ordering, information about casing diameters (OD and ID) is necessary.

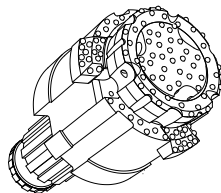

CDS-R pilot bit

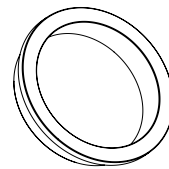
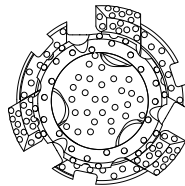

CDS-R impact shoe

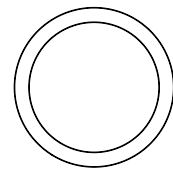

## CDS-RS

Order code	Pipe				Pilot bit				Wings [pcs]	Hammer [kg]	Weight [kg]	
	[mm]	[in]	[mm]	[in]	[mm]	[in]	[mm]	[in]				
CDS 360RS	406,4	16	25,4	1.000	438	17.244	360	14.173	3	12"	380.0	27.0
CDS 365RS	406,4	16	19,4	0.764	438	17.244	365	14.370	3	14"	401.0	27.0
CDS 460RS	508	20	25	0.984	540	21.260	460	18.110	3	14"	1350.0	40.0
CDS 510RS	559	22	26	1.024	583	22.953	510,5	20.100	3	14-18"	1230.0	28.0
CDS 560RS	610	24	20	0.787	640	25.197	560	22.047	3	18"	1350.0	30.0
CDS 610RS	660	26	27	1.063	692	27.244	610	24.016	3	18-24"	1790.0	36.0
CDS 660RS	762	30	25,4	1.000	792	31.180	661,5	26.040	3	18-24"	1970.0	49.0
CDS 745RS	813	32	33	1.299	843	33.189	746	29.370	4	24"	2500.0	55.0
CDS 835RS	914,4	36	42,4	1.669	950	37.400	835	32.874	4	24"	2860.0	70.0

When ordering, information about casing diameters (OD and ID) is necessary.

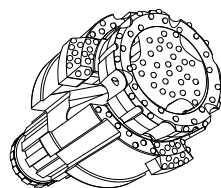

CDS-RS pilot bit

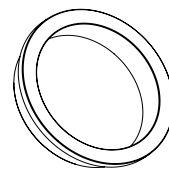
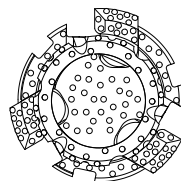

CDS-RS impact shoe

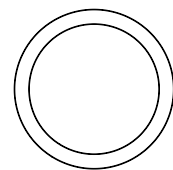

# Pilot & Ring Bits

## DTH-REC

Order code	Pipe				Pilot bit				Hammer	Weight	
	[mm]	[in]	[mm]	[in]	[mm]	[in]	[mm]	[in]			
DTH-REC 114,3/6	114,3	4½	6	0.236	89	3.503	125	4.921	3"	12	1.2
DTH-REC 139,7/5,6	139,7	5½	5,6	0.220	114	4.488	153	6.023	4"	22	1.5
DTH-REC 168,3/5,6	168,3	6¾	5,6	0.220	139,5	5.492	185	7.283	5"	36	2.5
DTH-REC 193,7/5	193,7	7¾	5	0.196	163	6.417	212	8.346	6"	57	3.5
DTH-REC 219,1/6,3	219,1	8¾	6,3	0.248	188,5	7.421	238	9.370	6"	79	4.0
DTH-REC 273/6,3	273	10¾	6,3	0.248	236	9.291	307	12.086	8"	136	6.5

When ordering, information about casing diameters (OD and ID) is necessary.

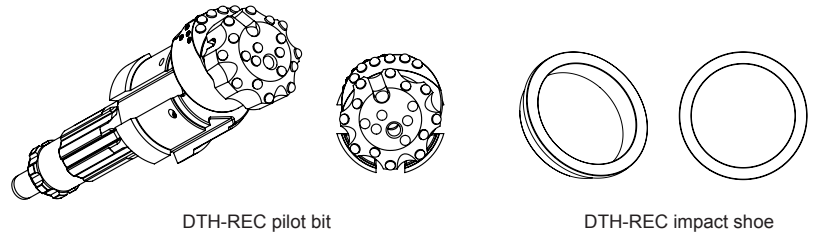

DTH-REC pilot bit

DTH-REC impact shoe

## OD

Order code	Ground bit				Buttons				Drill through button bits	Weight
	[mm]	[in]	[mm]	[in]	[No.]	[mm]	[No.]	[mm]		
H 105	67	2 5/8	104	4.094	4 x 9	8 x 9			38C64SGB	2.6
OD 110	72	2 7/8	110	4.331	4 x 9	8 x 9			HTG 38C70DRB, 38R70AGB	3.2
OD 131	92,5	3 5/8	131	5.157	6 x 9	12 x 12			HTG 45C89DB	5.2

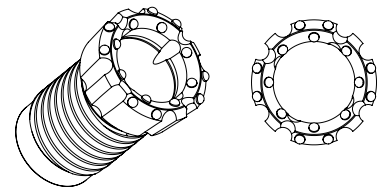

OD bit

## Pile Rammers

When finalizing the piling work, pilot bit will be pulled out of the casing and casing should be rammed to the bottom of the hole. For that operation Robit has a suitable tool to plug to the pilot bit and finalize piling without a risk to damage the pilot bit. When ordering the Robit® Pile Rammer, the pilot type and diameter info is needed.

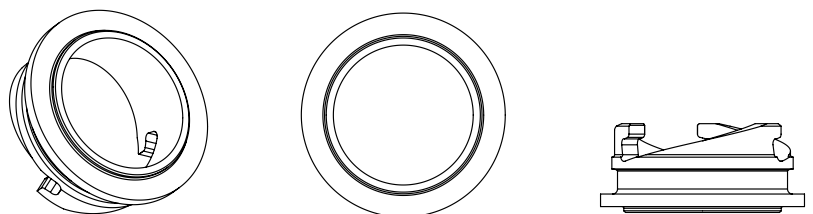

Pile Rammer

# Rotary Drill Bits Water Well

## Air Bearing (AB) Tungsten Carbide Insert (TCI) Series

Order code	Diameter		IADC	Formation	Pin size	Weight [kg]
	[mm]	[in]				
AB TCI Rotary Bit 2 1/2	64	2 1/2	521/721	Medium, Hard	N Rod	2,2
AB TCI Rotary Bit 2 5/8	67	2 5/8	521/721	Medium, Hard	N Rod	2,2
AB TCI Rotary Bit 2 7/8	73	2 7/8	721	Hard	N Rod	2,4
AB TCI Rotary Bit 2 15/16	75	2 15/16	721	Hard	N Rod	2,4
AB TCI Rotary Bit 3	76	3	521/721	Medium, Hard	N Rod	2,4
AB TCI Rotary Bit 3 1/8	79	3 1/8	521	Soft, Medium	N Rod	2,4
AB TCI Rotary Bit 3 1/2	89	3 1/2	521/721	Medium, Hard	2 3/8" API Reg	3,4
AB TCI Rotary Bit 3 7/8	98	3 7/8	521/621	Soft, Medium, Hard	2 3/8" API Reg	4,4
AB TCI Rotary Bit 4	101	4	521/721	Soft, Medium, Hard	2 3/8" API Reg	4,4
AB TCI Rotary Bit 4 1/8	105	4 1/8	521	Soft, Medium	2 3/8" API Reg	5,0
AB TCI Rotary Bit 4 1/4	108	4 1/4	521	Soft, Medium	2 3/8" API Reg	5,0
AB TCI Rotary Bit 4 1/2	114	4 1/2	521/721	Soft, Medium, Hard	2 3/8" API Reg	5,4
AB TCI Rotary Bit 4 3/4	121	4 3/4	521/721	Soft, Medium, Hard	2 7/8" API Reg	7,8
AB TCI Rotary Bit 4 5/8	117	4 5/8	521	Soft, Medium	2 7/8" API Reg	5,4
AB TCI Rotary Bit 4 7/8	124	4 7/8	721	Hard	2 7/8" API Reg	9,2
AB TCI Rotary Bit 5	127	5	721	Hard	2 7/8" API Reg	9,2
AB TCI Rotary Bit 5 1/8	130	5 1/8	521/721	Soft, Medium, Hard	2 7/8" API Reg	9,5
AB TCI Rotary Bit 5 1/4	133	5 1/4	521	Soft, Medium	2 7/8" API Reg	9,9
AB TCI Rotary Bit 5 3/8	137	5 3/8	521	Soft, Medium	2 7/8" API Reg	9,9
AB TCI Rotary Bit 5 1/2	140	5 1/2	521/721	Soft, Medium, Hard	2 7/8" API Reg	12,0
AB TCI Rotary Bit 5 5/8	143	5 5/8	521	Soft, Medium	3 1/2" API Reg	12,0
AB TCI Rotary Bit 5 3/4	146	5 3/4	721	Hard	3 1/2" API Reg	12,0
AB TCI Rotary Bit 5 7/8	149	5 7/8	521	Soft, Medium	3 1/2" API Reg	14,6
AB TCI Rotary Bit 6	152	6	521/621/721	Soft, Medium, Hard	3 1/2" API Reg	14,6
AB TCI Rotary Bit 6 1/8	156	6 1/8	521	Soft, Medium	3 1/2" API Reg	14,6
AB TCI Rotary Bit 6 1/4	159	6 1/4	521	Soft, Medium	3 1/2" API Reg	16,0
AB TCI Rotary Bit 6 1/2	165	6 1/2	521/721	Soft, Medium, Hard	3 1/2" API Reg	18,5
AB TCI Rotary Bit 6 3/4	171	6 3/4	521/721	Soft, Medium, Hard	3 1/2" API Reg	18,5
AB TCI Rotary Bit 7	178	7	521	Soft, Medium	3 1/2" API Reg	18,5
AB TCI Rotary Bit 7 3/8	187	7 3/8	721	Hard	3 1/2" API Reg	18,5
AB TCI Rotary Bit 7 1/2	191	7 1/2	521	Soft, Medium	4 1/2" API Reg	25,0
AB TCI Rotary Bit 7 7/8	200	7 7/8	721	Hard	4 1/2" API Reg	28,0
AB TCI Rotary Bit 9 1/2	241	9 1/2	521	Soft, Medium	4 1/2" API Reg	38,0

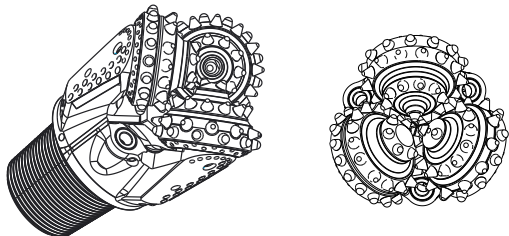
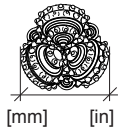



AB TCI Rotary Drill Bit

FURTHER. FASTER.

# Rotary Drill Bits Water Well

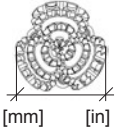
## Air Bearing (AB) Steel Tooth (ST) Series

Order code	Diameter		IADC	Formation	Pin size	Weight
						
	[mm]	[in]				[kg]
AB ST Rotary Bit 2 1/2	64	2 1/2	111/231/321	Soft, Medium, Hard	N Rod	1,7
AB ST Rotary Bit 2 5/8	67	2 5/8	111/231/321	Soft, Medium, Hard	N Rod	1,7
AB ST Rotary Bit 2 7/8	73	2 7/8	111/231/321	Soft, Medium, Hard	N Rod	2,0
AB ST Rotary Bit 2 15/16	75	2 15/16	111/231/321	Soft, Medium, Hard	N Rod	2,0
AB ST Rotary Bit 3	76	3	111/231/321	Soft, Medium, Hard	N Rod	2,0
AB ST Rotary Bit 3 1/2	89	3 1/2	111/231/321	Soft, Medium, Hard	2 3/8" API Reg	3,1
AB ST Rotary Bit 3 3/4	95	3 3/4	111/231/321	Soft, Medium, Hard	2 3/8" API Reg	3,7
AB ST Rotary Bit 3 7/8	98	3 7/8	111/231/321	Soft, Medium, Hard	2 3/8" API Reg	3,7
AB ST Rotary Bit 4	101	4	111/231/321	Soft, Medium, Hard	2 3/8" API Reg	3,8
AB ST Rotary Bit 4 1/8	105	4 1/8	111/231/321	Soft, Medium, Hard	2 3/8" API Reg	4,2
AB ST Rotary Bit 4 1/4	108	4 1/4	111/231/321	Soft, Medium, Hard	2 3/8" API Reg	4,2
AB ST Rotary Bit 4 1/2	114	4 1/2	111/231/321	Soft, Medium, Hard	2 3/8" API Reg	4,2
AB ST Rotary Bit 4 3/4	121	4 3/4	111/231/321	Soft, Medium, Hard	2 7/8" API Reg	7,3
AB ST Rotary Bit 4 7/8	124	4 7/8	111/231/321	Soft, Medium, Hard	2 7/8" API Reg	6,6
AB ST Rotary Bit 5	127	5	111/231/321	Soft, Medium, Hard	2 7/8" API Reg	6,8
AB ST Rotary Bit 5 1/8	130	5 1/8	111/231/321	Soft, Medium, Hard	2 7/8" API Reg	8,5
AB ST Rotary Bit 5 1/4	133	5 1/4	111/231/321	Soft, Medium, Hard	2 7/8" API Reg	8,5
AB ST Rotary Bit 5 3/8	137	5 3/8	111/231/321	Soft, Medium, Hard	2 7/8" API Reg	8,5
AB ST Rotary Bit 5 1/2	140	5 1/2	111/231/321	Soft, Medium, Hard	2 7/8" API Reg	9,2
AB ST Rotary Bit 5 5/8	143	5 5/8	111/231/321	Soft, Medium, Hard	3 1/2" API Reg	9,2
AB ST Rotary Bit 5 7/8	149	5 7/8	111/231/321	Soft, Medium, Hard	3 1/2" API Reg	13,7
AB ST Rotary Bit 6	152	6	111/231/321	Soft, Medium, Hard	3 1/2" API Reg	13,7
AB ST Rotary Bit 6 1/8	156	6 1/8	111/231/321	Soft, Medium, Hard	3 1/2" API Reg	13,7
AB ST Rotary Bit 6 1/4	159	6 1/4	311/111	Soft, Hard	3 1/2" API Reg	14,8
AB ST Rotary Bit 6 1/2	165	6 1/2	111/231/321	Soft, Medium, Hard	3 1/2" API Reg	16,5
AB ST Rotary Bit 6 3/4	171	6 3/4	111/231/321	Soft, Medium, Hard	3 1/2" API Reg	16,5
AB ST Rotary Bit 7	178	7	111/231/321	Soft, Medium, Hard	3 1/2" API Reg	16,5
AB ST Rotary Bit 7 1/2	191	7 1/2	111/231/321	Soft, Medium, Hard	4 1/2" API Reg	22,0
AB ST Rotary Bit 7 5/8	194	7 5/8	111/231/321	Soft, Medium, Hard	4 1/2" API Reg	22,0
AB ST Rotary Bit 7 7/8	200	7 7/8	111/231/321	Soft, Medium, Hard	4 1/2" API Reg	22,0
AB ST Rotary Bit 8	203	8	111/231/321	Soft, Medium, Hard	4 1/2" API Reg	23,0
AB ST Rotary Bit 8 1/2	216	8 1/2	111/231/321	Soft, Medium, Hard	4 1/2" API Reg	32,0
AB ST Rotary Bit 9 1/2	241	9 1/2	111/231/321	Soft, Medium, Hard	4 1/2" API Reg	32,0
AB ST Rotary Bit 9 7/8	251	9 7/8	111/231/321	Soft, Medium, Hard	6 5/8" API Reg	46,0
AB ST Rotary Bit 10	254	10	321	Hard	6 5/8" API Reg	46,0
AB ST Rotary Bit 12 1/4	311	12 1/4	111/231/321	Soft, Medium, Hard	6 5/8" API Reg	78,0

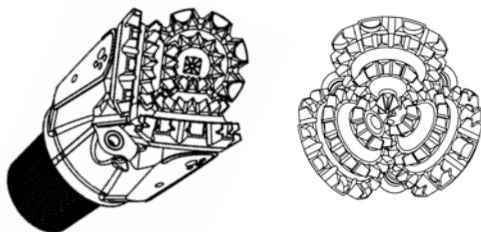

AB ST Rotary Drill Bit

Order code	DTH Hammer	Diameter		*Weight [kg]	Face type		
		[mm]	[in]		Flat	Convex	Concave
DTH-Bit 90/3"	3"	90	3½"	3,4		x	
DTH-Bit 95/3"	3"	95	3¾"	3,8		x	
DTH-Bit 100/3"	3"	100	4	4,4		x	
DTH-Bit 105/4"	4"	105	4⅛"	8,4		x	
DTH-Bit 110/4"	4"	110	4⅜"	8,8	x	x	
DTH-Bit 115/4"	4"	115	4½"	9	x	x	
DTH-Bit 127/4"	4"	127	5	9,9	x	x	
DTH-Bit 127/5"	5"	127	5	15,6	x	x	
DTH-Bit 140/5"	5"	140	5½"	17,4	x	x	
DTH-Bit 152/5"	5"	152	6	18,9	x	x	
DTH-Bit 152/6"	6"	152	6	25,5	x		x
DTH-Bit 165/6"	6"	165	6½"	26,3	x		x
DTH-Bit 200/8"	8"	200	7⅞"	33,8			x
DTH-Bit 203/6"	6"	203	7	32,6	x		x
DTH-Bit 203/8"	8"	203	7	34,5			x
DTH-Bit 216/6"	6"	216	8½"	34,4	x		x
DTH-Bit 216/8"	8"	216	8½"	37,5			x
DTH-Bit 254/6"	6"	254	10	45,0			x
DTH-Bit 254/8"	8"	254	10	51,5			x
DTH-Bit 305/12"	12"	305	12	159			x
DTH-Bit 311/12"	12"	311	12¼"	166			x
DTH-Bit 381/12"	12"	381	15	233			x
DTH-Bit 445/12"	12"	445	17½"	312			x
DTH-Bit 445/14"	14"	445	17½"	396			x
DTH-Bit 457/14"	14"	457	18	401			x
DTH-Bit 457/18"	18"	457	18	556			x
DTH-Bit 508/14"	14"	508	20	484			x
DTH-Bit 508/18"	18"	508	20	589			x
DTH-Bit 559/14"	14"	559	22	525			x
DTH-Bit 559/18"	18"	559	22	635			x
DTH-Bit 584/18"	18"	584	23	692			x
DTH-Bit 610/18"	18"	610	24	718			x
DTH-Bit 610/24"	24"	610	24	985			x
DTH-Bit 660/24"	24"	660	26	1058			x
DTH-Bit 711/24"	24"	711	28	2475			x
DTH-Bit 762/24"	24"	762	30	2622			x
DTH-Bit 813/24"	24"	813	32	3225			x
DTH-Bit 866/24"	24"	866	34	3410			x

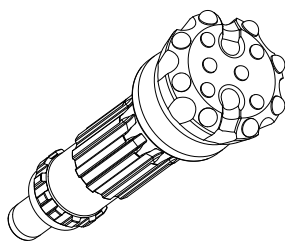

Flat face

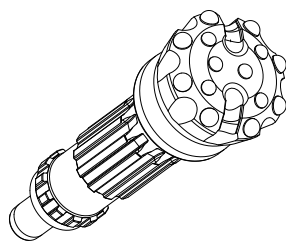

Convex face

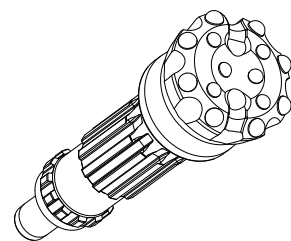

Concave face

\*Weight varies due to shank, face and button design.

All inquiries for shank designs please contact Robit sales.

# DTH Hammers

Order code	DTH Hammer	Shank	Backhead thread	Outside diameter		Length		Weight [kg]	Piston weight [kg]
				[mm]	[in]	[mm]	[in]		
BR1	1"	BR1	RD40	51	2.008	709	27.913	8	1
BR2	2"	BR2	RD50	62	2.441	838	32.992	13	1,8
BR33	3¼"	BR33	2¾ reg pin	82	3.225	768	30.236	25	3,3
Hyper 31	3"	Mach 33/IR3,5	2¾ reg pin	79,2	3.118	832	32.756	22,5	4,9
Hyper 41	4"	DHD340/SD4	2¾ reg pin	95	3.740	942	37.087	35	8
Hyper 51	5"	DHD 350R/SD5/QL50	3½ reg pin	114,3	4.500	1060	41.732	55	12,2
Hyper 63	6"	DHD360/SD6/QL60	3½ reg pin	143	5.630	1124	44.252	90	21
Hyper 81	8"	DHD380/COP84/SD8	4½ reg pin	184	7.244	1262	49.685	158	43,9
Hyper 101	10"	SD10/N100	6¾ reg pin	225	8.858	1575	62.008	338	68
Hyper 121	12"	DHD112	6¾ reg pin	272	10.709	1857	73.110	676	112
		N120	6¾ reg pin	272	10.709	1889	74.370	675	125
		SD12	6¾ reg pin	272	10.709	1909	75.157	675	125
		QL120	6¾ reg pin	286	11.260	1889	74.370	763	125
Hyper 125	12½"	N125	6¾ reg pin	305	12.008	1890	74.409	895	125
Hyper 141	14"	N125	6¾ reg pin	320	12.598	1941	76.417	1100	188
Hyper 181	18"	N180	8¾ reg pin	406	15.984	2185	86.024	1608	330
		SD18	8¾ reg pin	406	15.984	2255	88.780	1608	330
		QL200	8¾ reg pin	406	15.984	2147	84.528	1608	330
		QL200S	8¾ reg pin	406	15.984	2303	90.669	1748	330
Hyper 241	24"	N240	8¾ reg pin	533	20.984	2355	92.717	2510	580
Hyper 241S	24S"	XL24/32	10" Beco pin	745	29.331	2540	100	4000	630
Hyper 331	33"	H331	10" Beco pin	736,6	29.000	2540	100	5567	1552

All inquiries for other shank designs and backhead threads please contact Robit sales.



# Shock Absorbers

Order code	DTH Hammer	Top connector	Bottom connector	Outside diameter		Length		Weight [kg]
				[mm]	[in]	[mm]	[in]	
Shock Absorber 2"	2"	2 $\frac{3}{8}$ " reg pin	2 $\frac{3}{8}$ " reg box	62,0	2.441	346	13.622	7,5
Shock Absorber 3"	3"	2 $\frac{3}{8}$ " reg pin	2 $\frac{3}{8}$ " reg box	79,4	3.126	457	17.992	14,3
Shock Absorber 4"	4"	2 $\frac{3}{8}$ " reg pin	2 $\frac{3}{8}$ " reg box	95,4	3.756	483	19.016	22,1
Shock Absorber 5"	5"	3 $\frac{1}{2}$ " reg pin	3 $\frac{1}{2}$ " reg box	115,0	4.528	514	20.236	33,2
Shock Absorber 6"	6"	3 $\frac{1}{2}$ " reg pin	3 $\frac{1}{2}$ " reg box	140,0	5.512	578	22.756	53,0
Shock Absorber 8"	8"	4 $\frac{1}{2}$ " reg pin	4 $\frac{1}{2}$ " reg box	178,0	7.008	591	23.268	84,0
Shock Absorber 10"	10"	6 $\frac{5}{8}$ " reg pin	6 $\frac{5}{8}$ " reg box	216,0	8.504	635	25.000	98,0
Shock Absorber 12"	12" - 14"	6 $\frac{5}{8}$ " reg pin	6 $\frac{5}{8}$ " reg box	254,0	10.000	724	28.504	229,0
Shock Absorber 18"	18" - 24"	8 $\frac{5}{8}$ " reg pin	8 $\frac{5}{8}$ " reg box	406,0	15.984	711	27.992	598,0
Shock Absorber 30"	24" - 33"	10" Beco male	10" Beco female	508,0	20.000	950	37.402	1256,0



# Drill Pipes

Order code	Diameter		Wall thickness		Tool joint	Length		*Weight [kg*]
	D [mm]	[in]	T [mm]	[in]		L [mm]	[in]	
Drill pipe 76	76	2.992	4	0.157	2 $\frac{3}{8}$ " reg.	1000	39.370	12
						1500	59.055	16
						2000	78.740	19
						3000	118.110	26
						6000	236.220	47
			8,8	0.346	2 $\frac{3}{8}$ " reg.	1000	39.370	18
						1500	59.055	26
						2000	78.740	33
						3000	118.110	47
						6000	236.220	91
Drill pipe 89	89	3.504	4	0.157	2 $\frac{3}{8}$ " reg.	1000	39.370	16
						1500	59.055	21
						2000	78.740	25
						3000	118.110	33
						6000	236.220	58
			8,8	0.346	2 $\frac{3}{8}$ " reg.	1000	39.370	23
						1500	59.055	31
						2000	78.740	40
						3000	118.110	61
						6000	236.220	110



\*Weight can vary because of pipe joint details.

Order code	Diameter D		Wall thickness T		Tool joint	Length L		*Weight [kg*]
	[mm]	[in]	[mm]	[in]		[mm]	[in]	
Drill pipe 102	102	4.016	6,3	0.248	2 7/8" reg.	1000	39.370	25
						1500	59.055	33
						2000	78.740	40
						3000	118.110	55
						6000	236.220	100
Drill pipe 114	114	4.488	6,3	0.248	3 1/2" reg.	1000	39.370	29
						1500	59.055	38
						2000	78.740	46
						3000	118.110	63
						6000	236.220	114
Drill pipe 139	139	5.472	8,8	0.346	3 1/2" reg.	1000	39.370	45
						1500	59.055	59
						2000	78.740	76
						3000	118.110	104
						6000	236.220	187
						12000	472.441	370
Drill pipe 168	168	6.614	12,5	0.492	4 1/2" reg.	1000	39.370	120
						1500	59.055	145
						2000	78.740	170
						3000	118.110	228
						6000	236.220	396
						12000	472.441	605
Drill pipe 193	193	7.598	12,5	0.492	4 1/2" reg.	1000	39.370	126
						1500	59.055	154
						2000	78.740	181
						3000	118.110	236
						6000	236.220	410
						12000	472.441	745
Drill pipe 219	219	8.622	12,5	0.492	4 1/2" reg.	1000	39.370	159
						1500	59.055	191
						2000	78.740	222
						3000	118.110	285
						6000	236.220	475
						12000	472.441	857
Drill pipe 254	254	10.000	12,5	0.492	6 5/8" reg.	1000	39.370	222
						1500	59.055	259
						2000	78.740	296
						3000	118.110	370
						6000	236.220	594
						12000	472.441	1041
HEX150						1000	39.370	204
						1500	59.055	241
						2000	78.740	279
						3000	118.110	354
						6000	236.220	577
						12000	472.441	1024
Drill pipe 273	273	10.748	16	0.630	6 5/8" reg.	1000	39.370	248
						1500	59.055	299
						2000	78.740	349
						3000	118.110	451
						6000	236.220	755
						12000	472.441	1363
HEX150						1000	39.370	282
						1500	59.055	333
						2000	78.740	383
						3000	118.110	484
						6000	236.220	788
						12000	472.441	1396
Drill pipe 323	323	12.717	16	0.630	6 5/8" reg.	1000	39.370	320
						1500	59.055	381
						2000	78.740	442
						3000	118.110	563
						6000	236.220	927
						12000	472.441	1654
HEX190						1000	39.370	360
						1500	59.055	421
						2000	78.740	482
						3000	118.110	603
						6000	236.220	966
						12000	472.441	1693

Ø 76 - 323 mm

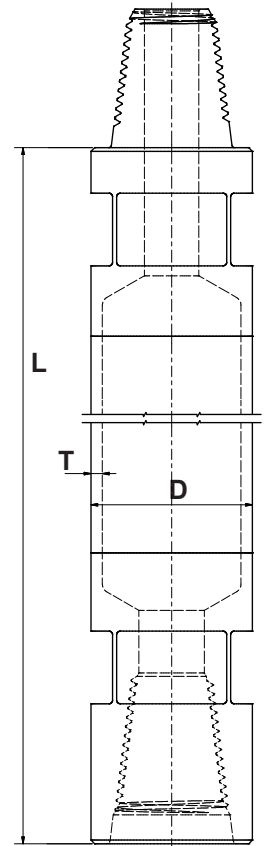

Ø 406 - 1220 mm

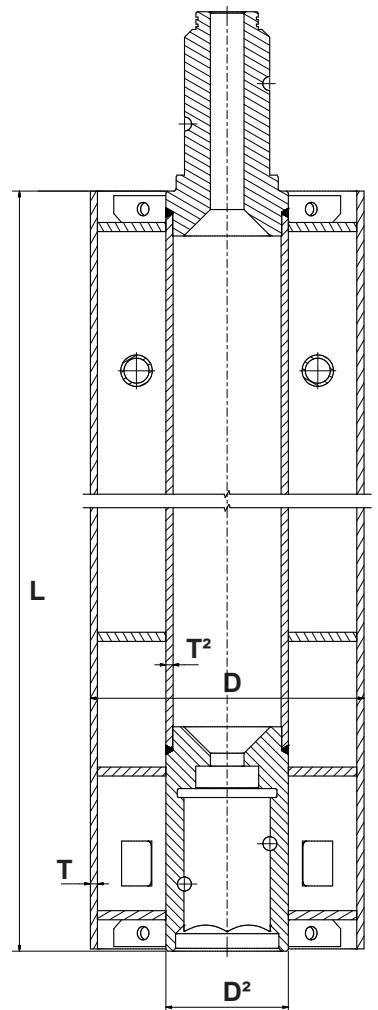

\*Weight can vary because of pipe joint details.



# Drill Pipes - Double Pipe

Order code	Diameter		Wall thickness		Diameter 2		Wall thickness 2		Tool joint	Length		*Weight [kg*]
	[mm]	D [in]	[mm]	T [in]	[mm]	D <sup>2</sup> [in]	[mm]	T <sup>2</sup> [in]		[mm]	L [in]	
Drill pipe 406	406	15.984	12,5	0.492	273	10.748	16	0.630	8 $\frac{5}{8}$ " reg.	1000	39.370	387
										1500	59.055	487
										2000	78.740	598
										3000	118.110	821
										6000	236.220	1507
										12000	472.441	2860
Drill pipe 457	457	17.992	12,5	0.492	273	10.748	16	0.630	8 $\frac{5}{8}$ " reg.	1000	39.370	401
										1500	59.055	521
										2000	78.740	640
										3000	118.110	878
										6000	236.220	1621
										12000	472.441	3079
Drill pipe 508	508	20.000	12,5	0.492	273	10.748	16	0.630	HEX190	1000	39.370	440
										1500	59.055	559
										2000	78.740	678
										3000	118.110	917
										6000	236.220	1660
										12000	472.441	3118
Drill pipe 559	559	22.008	12,5	0.492	323,9	12.752	16	0.630	HEX190	1000	39.370	611
										1500	59.055	756
										2000	78.740	901
										3000	118.110	1191
										6000	236.220	2105
										12000	472.441	3890
Drill pipe 610	610	24.016	12,5	0.492	323,9	12.752	16	0.630	HEX190	1000	39.370	641
										1500	59.055	794
										2000	78.740	947
										3000	118.110	1252
										6000	236.220	2228
										12000	472.441	4120
Drill pipe 711	711	27.992	12,5	0.492	323,9	12.752	16	0.630	HEX190	1000	39.370	704
										1500	59.055	872
										2000	78.740	1040
										3000	118.110	1377
										6000	236.220	2478
										12000	472.441	4589
Drill pipe 762	762	30.000	12,5	0.492	323,9	12.752	16	0.630	HEX190	1000	39.370	737
										1500	59.055	913
										2000	78.740	1090
										3000	118.110	1442
										6000	236.220	2608
										12000	472.441	4831
Drill pipe 813	813	32.008	12,5	0.492	323,9	12.752	16	0.630	HEX210	1000	39.370	772
										1500	59.055	956
										2000	78.740	1140
										3000	118.110	1508
										6000	236.220	2740
										12000	472.441	5077
Drill pipe 914	914	35.984	12,5	0.492	323,9	12.752	16	0.630	HEX210	1000	39.370	845
										1500	59.055	1044
										2000	78.740	1244
										3000	118.110	1643
										6000	236.220	3011
										12000	472.441	5576
Drill pipe 1016	1016	40.000	12,5	0.492	323,9	12.752	16	0.630	HEX210	1000	39.370	923
										1500	59.055	1139
										2000	78.740	1354
										3000	118.110	1785
										6000	236.220	3294
										12000	472.441	6095
Drill pipe 1220	1220	48.031	12,5	0.492	323,9	12.752	16	0.630	HEX210	1000	39.370	1094
										1500	59.055	1343
										2000	78.740	1590
										3000	118.110	2083
										6000	236.220	3891
										12000	472.441	7179

\*Weight can vary because of pipe joint details.

# Subs, Check Valves & Hammer Sleeves

Order code	Diameter		Top connector	Bottom connector	Length		Weight
	[mm]	[in]			[mm]	[in]	
Sub 76,1 - 2 $\frac{3}{8}$ REG box & pin L140	76,1	3	2 $\frac{3}{8}$ REG box	2 $\frac{3}{8}$ REG pin	140	5.512	4
Sub 88,9 - 2 $\frac{3}{8}$ REG box & pin L140	88,9	3 $\frac{1}{2}$	2 $\frac{3}{8}$ REG box	2 $\frac{3}{8}$ REG pin	140	5.512	5
Sub 88,9 - 2 $\frac{3}{8}$ REG box & pin L225	88,9	3 $\frac{1}{2}$	2 $\frac{3}{8}$ REG box	2 $\frac{3}{8}$ REG pin	225	8.858	9
Sub 88,9 - 2 $\frac{3}{8}$ REG box & pin L305	88,9	3 $\frac{1}{2}$	2 $\frac{3}{8}$ REG box	2 $\frac{3}{8}$ REG pin	305	12.008	12
Adapter 114,3 - 2 $\frac{3}{8}$ -3 $\frac{1}{2}$ REG box & pin L120	114,3	4 $\frac{1}{2}$	2 $\frac{3}{8}$ REG box	3 $\frac{1}{2}$ REG pin	120	4.724	10
Adapter 88,9 - 2 $\frac{3}{8}$ -2 $\frac{3}{8}$ REG box & pin L134	88,9	3 $\frac{1}{2}$	2 $\frac{3}{8}$ REG box	2 $\frac{3}{8}$ REG pin	134	5.276	5
Adapter 114,3 - 2 $\frac{3}{8}$ -3 $\frac{1}{2}$ REG box & pin L145	114,3	4 $\frac{1}{2}$	2 $\frac{3}{8}$ REG box	3 $\frac{1}{2}$ REG pin	145	5.709	8
Sub 114,3 - 3 $\frac{1}{2}$ REG box & pin L250	114,3	4 $\frac{1}{2}$	3 $\frac{1}{2}$ REG box	3 $\frac{1}{2}$ REG pin	250	9.843	16
Adapter 114,3/88,9 - 3 $\frac{1}{2}$ -2 $\frac{3}{8}$ REG box & pin L300	114,3/88,9	4 $\frac{1}{2}$ / 3 $\frac{1}{2}$	3 $\frac{1}{2}$ REG box	2 $\frac{3}{8}$ REG pin	300	11.811	17
Adapter 114,3 - 3 $\frac{1}{2}$ -2 $\frac{3}{8}$ REG box & pin L160	114,3	4 $\frac{1}{2}$	3 $\frac{1}{2}$ REG box	2 $\frac{3}{8}$ REG pin	160	6.299	9
Adapter 140 - 3 $\frac{1}{2}$ -2 $\frac{3}{8}$ REG box & pin L104	140	5 $\frac{1}{2}$	3 $\frac{1}{2}$ REG box	4 $\frac{1}{2}$ REG pin	104	4.094	13
Adapter 140/114,3 - 4 $\frac{1}{2}$ -3 $\frac{1}{2}$ REG box & pin L220	140/114,3	5 $\frac{1}{2}$ / 4 $\frac{1}{2}$	4 $\frac{1}{2}$ REG box	3 $\frac{1}{2}$ REG pin	220	8.661	16
Sub 140 - 4 $\frac{1}{2}$ REG box & pin L180	140	5 $\frac{1}{2}$	4 $\frac{1}{2}$ REG box	4 $\frac{1}{2}$ REG pin	180	7.087	18
Adapter 196,8/140 - 4 $\frac{1}{2}$ -6 $\frac{5}{8}$ REG box & pin L215	196,8/140	7 $\frac{3}{4}$ / 5 $\frac{1}{2}$	4 $\frac{1}{2}$ REG box	6 $\frac{5}{8}$ REG pin	215	8.465	30
Adapter 196,8/114,3 - 6 $\frac{5}{8}$ -3 $\frac{1}{2}$ REG box & pin L265	196,8/114,3	7 $\frac{3}{4}$ / 4 $\frac{1}{2}$	6 $\frac{5}{8}$ REG box	3 $\frac{1}{2}$ REG pin	265	10.433	28
Adapter 196,8/140 - 6 $\frac{5}{8}$ -4 $\frac{1}{2}$ REG box & pin L240	196,8/140	7 $\frac{3}{4}$ / 5 $\frac{1}{2}$	6 $\frac{5}{8}$ REG box	4 $\frac{1}{2}$ REG pin	240	9.449	31
Adapter 254 - 6 $\frac{5}{8}$ -150 REG box & Hex pin L300	254	10	6 $\frac{5}{8}$ REG box	Hex 150 pin	300	11.811	120
Adapter 254 - 150-6 $\frac{5}{8}$ Hex box & REG pin L350	254	10	Hex 150 box	6 $\frac{5}{8}$ REG pin	350	13.780	148
Adapter 273 - 6 $\frac{5}{8}$ -190 REG box & Hex pin L300	273	10 $\frac{3}{4}$	6 $\frac{5}{8}$ REG box	Hex 190 pin	300	11.811	207
Adapter 273 - 190-6 $\frac{5}{8}$ Hex box & REG pin L550	273	10 $\frac{3}{4}$	Hex 190 box	6 $\frac{5}{8}$ REG pin	550	21.654	188
Adapter 273 - 8 $\frac{5}{8}$ -190 REG box & Hex pin L300	273	10 $\frac{3}{4}$	8 $\frac{5}{8}$ REG box	Hex 190 pin	300	11.811	208
Adapter 273 - 190-8 $\frac{5}{8}$ Hex box & REG pin L550	273	10 $\frac{3}{4}$	Hex 190 box	8 $\frac{5}{8}$ REG pin	550	21.654	189
Adapter 323 - 6 $\frac{5}{8}$ -210 REG box & Hex pin L300	323	10 $\frac{3}{4}$	6 $\frac{5}{8}$ REG box	Hex 210 pin	300	11.811	322
Adapter 323 - 210-6 $\frac{5}{8}$ Hex box & REG pin L550	323	10 $\frac{3}{4}$	Hex 210 box	6 $\frac{5}{8}$ REG pin	550	21.654	296

Order code	Diameter		Top connector	Bottom connector	Length		Weight
	[mm]	[in]			[mm]	[in]	
Check valve 76,1 - 2 $\frac{3}{8}$ REG box & pin L140	76,1	3	2 $\frac{3}{8}$ REG box	2 $\frac{3}{8}$ REG pin	140	5.512	6
Check valve 88,9 - 2 $\frac{3}{8}$ REG box & pin L140	88,9	3 $\frac{1}{2}$	2 $\frac{3}{8}$ REG box	2 $\frac{3}{8}$ REG pin	140	5.512	7
Check valve 114,3 - 3 $\frac{1}{2}$ REG box & pin L210	114,3	4 $\frac{1}{2}$	3 $\frac{1}{2}$ REG box	3 $\frac{1}{2}$ REG pin	210	8.268	16
Check valve 127 - 3 $\frac{1}{2}$ REG box & pin L210	127	5	3 $\frac{1}{2}$ REG box	3 $\frac{1}{2}$ REG pin	210	8.268	19
Check valve 140 - 4 $\frac{1}{2}$ -3 $\frac{1}{2}$ REG box & pin L230	140	5 $\frac{1}{2}$	4 $\frac{1}{2}$ REG box	3 $\frac{1}{2}$ REG pin	230	9.055	24

Hammer sleeves for request. Please contact Robit® sales, tel. +358 3 3140 3400 or sales@robitgroup.com

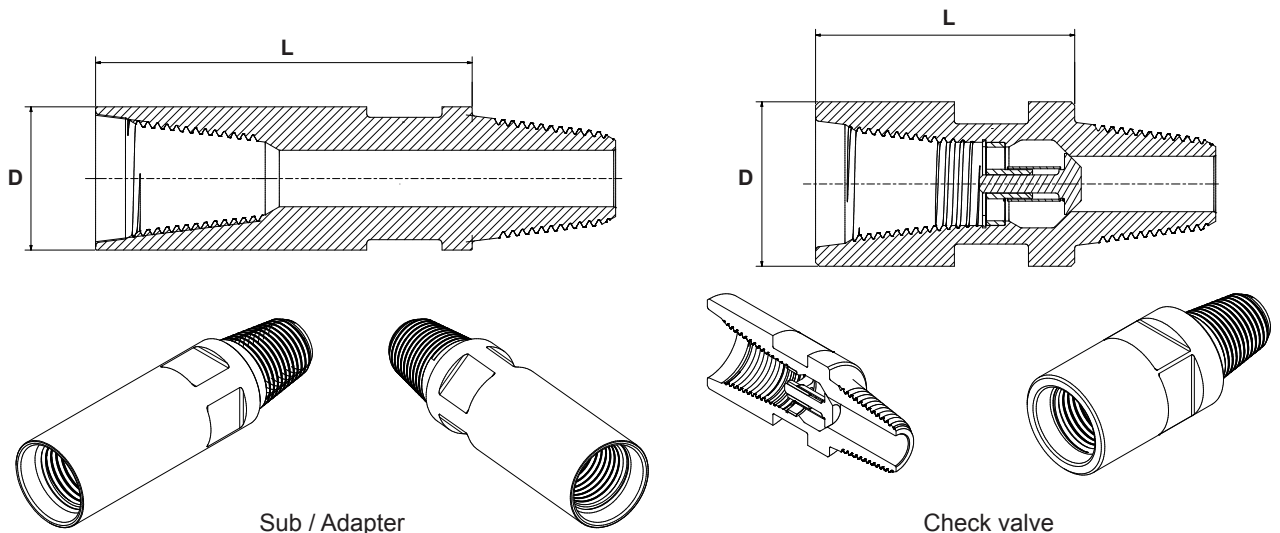

Sub / Adapter

Check valve

## Grinding cups & machines

### Grinding cups



Hexaconal shaft

Order code	Product number	Weight [kg]	Order code	Product number	Weight [kg]
<b>HEXAAGONAL SHAFT Round</b>			<b>HEXAAGONAL SHAFT Ballistic</b>		
Hexaconal 7 mm Round	06K-03-0805	0,06	Hexaconal 7 mm Ballistic	06K-03-0715	0,06
Hexaconal 8 mm Round	06K-03-0804	0,06	Hexaconal 8 mm Ballistic	06K-03-0710	0,06
Hexaconal 9 mm Round	06K-03-0803	0,06	Hexaconal 9 mm Ballistic	06K-03-2174	0,06
Hexaconal 10 mm Round	06K-03-0812	0,07	Hexaconal 10 mm Ballistic	06K-03-0739	0,07
Hexaconal 11 mm Round	06K-03-0811	0,07	Hexaconal 11 mm Ballistic	06K-03-0734	0,07
Hexaconal 12 mm Round	06K-03-0810	0,07	Hexaconal 12 mm Ballistic	06K-03-2176	0,07
Hexaconal 13 mm Round	06K-03-0809	0,07	Hexaconal 13 mm Ballistic	06K-03-0728	0,07
Hexaconal 14 mm Round	06K-03-0808	0,08	Hexaconal 14 mm Ballistic	06K-03-0724	0,08
Hexaconal 16 mm Round	06K-03-0806	0,08	Hexaconal 16 mm Ballistic	06K-03-0721	0,08
Hexaconal 18 mm Round	06K-03-3412	0,09	Hexaconal 18 mm Ballistic	06K-03-3413	0,09

### Grinding machines

Hand held grinding machine VS-220 HD  
Mini Junior (electric or pneumatic operating)



### Air hoses & chain keys

35 bar air hoses, lengths 20 m, 35 m and 40 m  
Hose covers



Chain key 3-5" & 3-8"  
Chain 3-5" DA2344-C12 & 3-8" DA4174-C12  
Key body 3-5" DA2344-C12 & 3-8" DA4174-C12



# Robit®

ROBIT PLC

Vikkiniityntie 9

FI-33880 LEMPÄÄLÄ (TAMPERE)

FINLAND

Tel: +358 3 3140 3400

E-mail: [sales@robitgroup.com](mailto:sales@robitgroup.com)

<http://www.robitgroup.com>

Your distributor:

